

Technical data and dimensions

Technical data and dimensions

Technical d

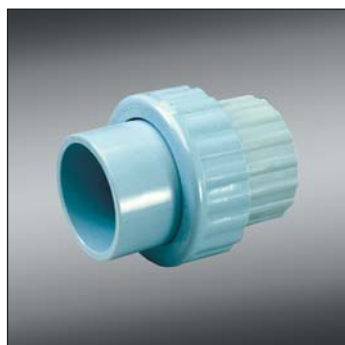

 Durapipe

air-line xtra

Technical data and dimensions

nsions

nsions

Technical data and dimensions

For further information on all Durapipe UK products and services contact our Internal Sales Department as detailed below.

**Durapipe UK**

Walsall Road  
Cannock  
Staffordshire  
WS11 9NS  
Tel: +44 (0)1543 279909  
Fax: +44 (0)1543 279450  
email: [enquiries@durapipe.co.uk](mailto:enquiries@durapipe.co.uk)  
web: [www.durapipe.co.uk](http://www.durapipe.co.uk)

**Distributor**

**Notes**



## Contents

Introduction	2
The system	3/4
Design and installation	5-14
Installation	15-17
Safety precautions	18
Compressor oil suitability	19/20
Product range dimensions	21-31

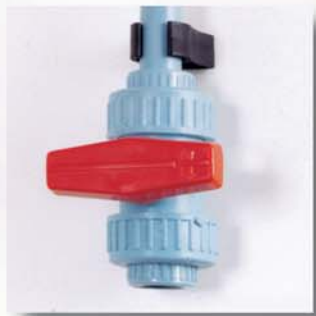



## Introduction

Compressed air, a major source of industrial energy, is being used increasingly in both the manufacturing and process industries where its distinct advantages of cleanliness, flexibility, safety and economy of use, compared with other energy sources, are fully exploited.

Modern process equipment, pneumatic controls and instrumentation, however, demand a supply of clean, uncontaminated air and this has necessitated the development in recent years of more advanced designs of compressors and ancillary equipment.

Maintenance of the cleanliness of this air, from source right up to the point of use is obviously essential. Hence air mains and branch lines are also required to be of an advanced design.

Durapipe Air-Line Xtra is a lightweight, non-corrodible compressed air distribution system from Durapipe *pipelines* which builds on the success of the original Durapipe Air-Line product. Durapipe Air-Line Xtra offers a wider field of applications and additional benefits. In addition to being fully compatible with the existing Durapipe Air-Line system, Durapipe Air-Line Xtra is also fully acceptable under the UK, 'Pressure Systems and Transportable Gas Container Regulations'.

Manufactured from a specially formulated ABS blend, Durapipe Air-Line Xtra pipe has a high performance co-extruded liner which greatly enhances its mechanical and chemical properties. Durapipe Air-Line Xtra fittings are manufactured using an alloy blend of ABS which ensures that the performance of the whole system is without equal.

The system is designed specifically for the conveyance of compressed air and with its new and unrivalled properties becomes the ideal choice for critical applications. DURAPIPE AIR-LINE XTRA KEEPS AIR CLEAN – RIGHT UP TO THE POINT OF USE.

### The advantages of Durapipe Air-Line Xtra pipework systems are:-

#### 1. Safety

The Butadiene constituent of Durapipe Air-Line Xtra affords resistance to accidental damage and prevents material fracture should the pipe be subjected to severe impact – even at sub-zero temperatures. Durapipe Air-Line Xtra has a design life of 30 years with a residual factor of safety of 2:1.

#### 2. Wide range of applications

The advanced liner and material combination protects against the stray chemicals which can sometimes cause problems for ordinary systems. Now compatible with even more compressor lubricants Durapipe Air-Line Xtra pipes and fittings carry a DIN 4102-B2 fire rating.

#### 3. Clean

Strong packaging protects the surface finish of pipe and fittings and prevents contamination before use. The smooth, hygienic liner is impressively clean when new and cannot rust, corrode or form loose scale. Clean air remains clean throughout the life of the system.

#### 4. Non toxic

Durapipe Air-Line Xtra has been proved to be safe for both medical and everyday applications.

#### 5. Smooth bore

Less friction means lower pressure drops and higher flow rates – this may allow smaller pipes to be used.

#### 6. Easy to handle

One sixth the weight of steel.

#### 7. Quick to joint

No threading required – jointed by cold solvent welding. Easy on-site modification and repair.

#### 8. Speed of installation

No special equipment or special skills required.

#### 9. Leak free system

Leakage cannot occur from a correctly made solvent welded joint, greatly reducing running costs.

#### 10. Self coloured and maintenance free

Light blue in accordance with British Standards requirements – BS 4800 and BS 1710. No painting or maintenance necessary.

#### 11. Acceptable under UK regulations

Further details of the UK 'Pressure Systems and Transportable Gas Container Regulations' are available on request.

#### 12. Proven

Durapipe Air-Line systems have been giving satisfactory service since 1976 and now through laboratory and field trials have proved the superiority of Durapipe Air-Line Xtra.

## Quality

All pipes, fittings and valves are manufactured in an environment operating a quality system which has been successfully assessed to BS EN ISO 9001.



As part of this Quality System both raw materials and finished Durapipe Air-Line Xtra products are subjected to rigorous quality control tests. In addition, long term pressure tests together with ageing, weathering and stressed environmental tests are carried out to ensure complete system integrity over the designed operating life.

## Environment

We also operate an environmental management system that has been successfully assessed against BS EN ISO 14001 environmental management standard.

## Technical back-up

From manufacture to marketplace, Durapipe Air-Line Xtra is supported by the technical experience gained over four decades of thermoplastics pressure pipework production.

Durapipe Air-Line Xtra is supported by our own Research and Development facilities plus a team of specialist Technical Support Engineers, which is readily available to give its expert advice on any aspect of the product.

This Users Guide serves to outline the design and installation techniques required to achieve a safe, high integrity system. Further details can be obtained from our Technical Support Department.



## The system

### ABS material

Acrylonitrile-Butadiene-Styrene (ABS) identifies a broad family of engineering thermoplastics with a range of performance characteristics.

This copolymeric material can be blended to yield the optimum balance of properties suited to a selected end use. Acrylonitrile imparts chemical resistance and rigidity, The Butadiene constituent gives the material impact strength and toughness, whilst Styrene contributes to ease of processing and good surface finish.

The formulation used for Durapipe Air-Line Xtra has been selected to optimise performance in respect of tensile strength, toughness, ductility, heat stability and processability – from raw material to finished product. These properties make it suitable for conveying compressed air.

ABS has good chemical resistance and is easily joined by solvent welding which allows fast system assembly and modification.

### The system

Advanced manufacturing techniques allow the formation of a liner layer in the pipe bore. The liner is a high performance copolymeric material which offers extra strength (because it is permanently fused with the outer, ABS layer during the extrusion process) together with an unrivalled level of chemical resistance.

Fittings are produced in an alloy blend of ABS and the liner material which has been carefully balanced to achieve a performance improvement to match the new pipe.

In common with ABS materials, Durapipe Air-Line Xtra can suffer stress attack if exposed to some compressor oils. A list of suitable oils is shown on pages 19/20. If in doubt always check before installation. The system offers resistance to the stray aggressive substances which can sometimes contaminate compressed air pipelines and which can cause problems for other thermoplastic materials.

Durapipe Air-Line Xtra retains the simplicity and strength of ABS welded joints. It is a system which offers reliability and durability even in the most arduous operating environment.

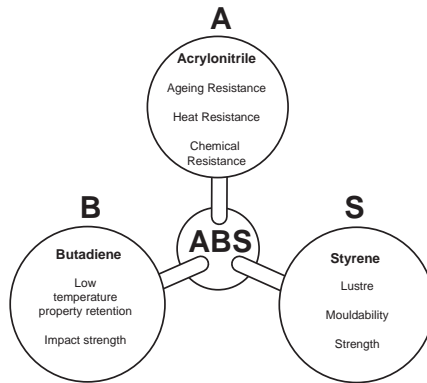

The above photograph compares the effects of impact upon ABS and PVC-U pipes, under similar pressure conditions. Comparing the brittle fracture mode exhibited by the PVC-U material, highlights why this material should never be used for compressed air applications.

### Operational range

The Durapipe Air-Line Xtra system is designed for a maximum continuous service pressure of 12.5 bar at 20°C. Any increase in working temperature above 20°C will necessitate a corresponding reduction in pressure rating as detailed on page 5.

### Valves

Double union ball valves, diaphragm valves and butterfly valves are available for use with the Durapipe Air-Line Xtra system, and are featured on pages 29, 30 and 31.

### Size range

The Durapipe Air-Line Xtra range is produced in the following metric sizes: 16, 20, 25, 32, 40, 50, 63, 75, 90 and 110mm.

It should be noted that these are outside diameters – pipes being sized and designated by the outside diameter. For convenience the equivalent sizes of Durapipe Air-Line Xtra, galvanised mild steel and copper are compared in the table below.

NB. The smooth bore of Durapipe Air-Line Xtra pipes and fittings allows a smaller pipe to be used for a given air flow – refer to page 7.

Air-Line Xtra		Galvanised mild-steel BS 1387				Copper	
nominal o/d mm	12.5 bar weight kg/m	Nominal bore in	Actual o/d mm	Light weight kg/m	Heavy weight kg/m	BS 2871 pt 1 table x o/d mm	weight kg/m
16	0.1	3/8	17.2	0.67	0.69	15.00	0.28
20	0.13	1/2	21.3	0.95	1.45	18.00	0.38
25	0.18	3/4	26.9	1.41	1.90	22.00	0.53
32	0.28	1	33.7	2.01	2.97	28.00	0.68
40	0.46	1 1/4	42.4	3.14	3.84	35.00	1.11
50	0.69	1 1/2	48.3	3.25	4.43	42.00	1.37
63	1.09	2	60.3	4.11	6.17	54.00	1.77
75	1.54	2 1/2	76.1	5.80	7.90	67.00	2.23
90	2.23	3	88.9	6.81	10.10	76.10	3.13
110	3.31	4	114.3	9.89	14.40	108.00	4.47

NB. 'Light' as shown in the table is a British Standard 1387 description.

## Dimensions and standards

The outside diameters of the pipes comply with the dimensional requirements of DIN 8062, and ISO 161/1. The socket sizes of the fittings conform with the dimensional requirements of DIN 8063 and ISO 727. The sockets of the fittings have a 0° 30' taper, the diameter decreasing from the mouth to the root.

All dimensions in this brochure are shown in millimetres with the exception of threaded fittings which conform to the nominal requirements of BS 21, DIN 2999 Part 1 and ISO 7 Part 1.

All Durapipe Air-Line Xtra threaded fittings have taper threads with the exceptions of the female composite unions, the inlet to the multiport wall bracket.

The table below shows the socket dimensions for the whole range.

Ød <sub>1</sub>	NW	A	B	
			Min	Max
16	10	14	16.1	16.3
20	15	16	20.1	20.3
25	20	18.5	25.1	25.3
32	25	22	32.1	32.3
40	32	26	40.1	40.3
50	40	31	50.1	50.3
63	50	37.5	63.1	63.3
75	65	43.5	75.1	75.3
90	80	51	90.1	90.3
110	100	61	110.1	110.4

Ød<sub>1</sub> = Pipe outside diameter  
 NW = Nominal bore  
 A = Minimum socket depth  
 B = Mid mean socket diameter at mid mean point of socket depth.

## Z – length installation method

As an aid to installation, Z-lengths have been added to the dimensional details of fittings shown in this section. The basic idea is to assist in the prefabrication of pipe sections and to avoid time consuming and costly piecemeal preparation of short lengths and fittings on an individual basis. By using Z-lengths, as many measurements as possible are taken at one time and pipe sections can be readily pre-assembled away from the job site.

To fabricate pipe assemblies from sketches giving centre-line dimensions it is necessary to know the distance from the perpendicular centre line of the fitting to the beginning of the pipe and in the case of sockets and similar fittings, the pipe stop length. These are the 'Z-lengths' and are the key to easy fabrication.

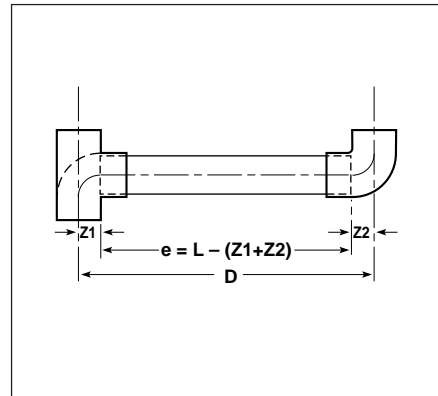

By subtracting the sum of the Z dimensions of the two fittings from the centre-to-centre measurement, the length of pipe required can be quickly determined. Thus the cutting length required, (e), is obtained by subtracting the sum of the 2 lengths (Z<sub>1</sub> + Z<sub>2</sub>), from the centre-line measurement, (L).

## Reducing sockets

Durapipe Air-Line Xtra reducers incorporate 3 controlled diameters offering a wider range than usual for each fitting, see page 17.

The smaller end is socketed only, whilst the larger end can be used either as a spigot or a socket.

## Adaptor pipe fittings

Female threaded adaptors incorporate 2 controlled diameters on the plain end and can be used as spigot or socket, giving a wider range of use than usual – see page 17.

## Marking

Most Durapipe Air-Line Xtra fittings incorporate the following information moulded on during manufacture. Other fittings are marked by printing.

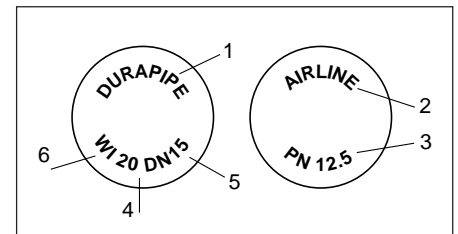

- 1 Name or Trade Mark: Durapipe or DF
- 2 Material – Co-polymer ABS
- 3 Pressure Rating: PN 12.5
- 4 Size
- 5 Nominal Bore
- 6 DIN Standard form designation mark e.g. W1 – 90° elbow

## Standard pack

The Standard Pack quantity for each size of fitting is shown in this brochure under the heading SP. The standard length of pipe denoted under SL.

## Weight

The weight of the fittings in grammes is shown in the appropriate column for each fitting.



## Design and installation

### Pressure/Temperature parameters

The maximum continuous working pressure of the PN 12.5 Durapipe Air-Line Xtra system is 12.5 bar at 20°C.

This pressure must not be continuously exceeded or a reduced service life will result.

Transient increases in pressure can be tolerated up to a maximum of 10% over the maximum continuous pressure at a given temperature.

For increased compressed air temperatures the pressure rating of Durapipe Air-Line Xtra should be correspondingly reduced, as indicated in the graph below. For example, at 50°C the PN 12.5 system can be operated continuously up to 8 bar internal pressure.

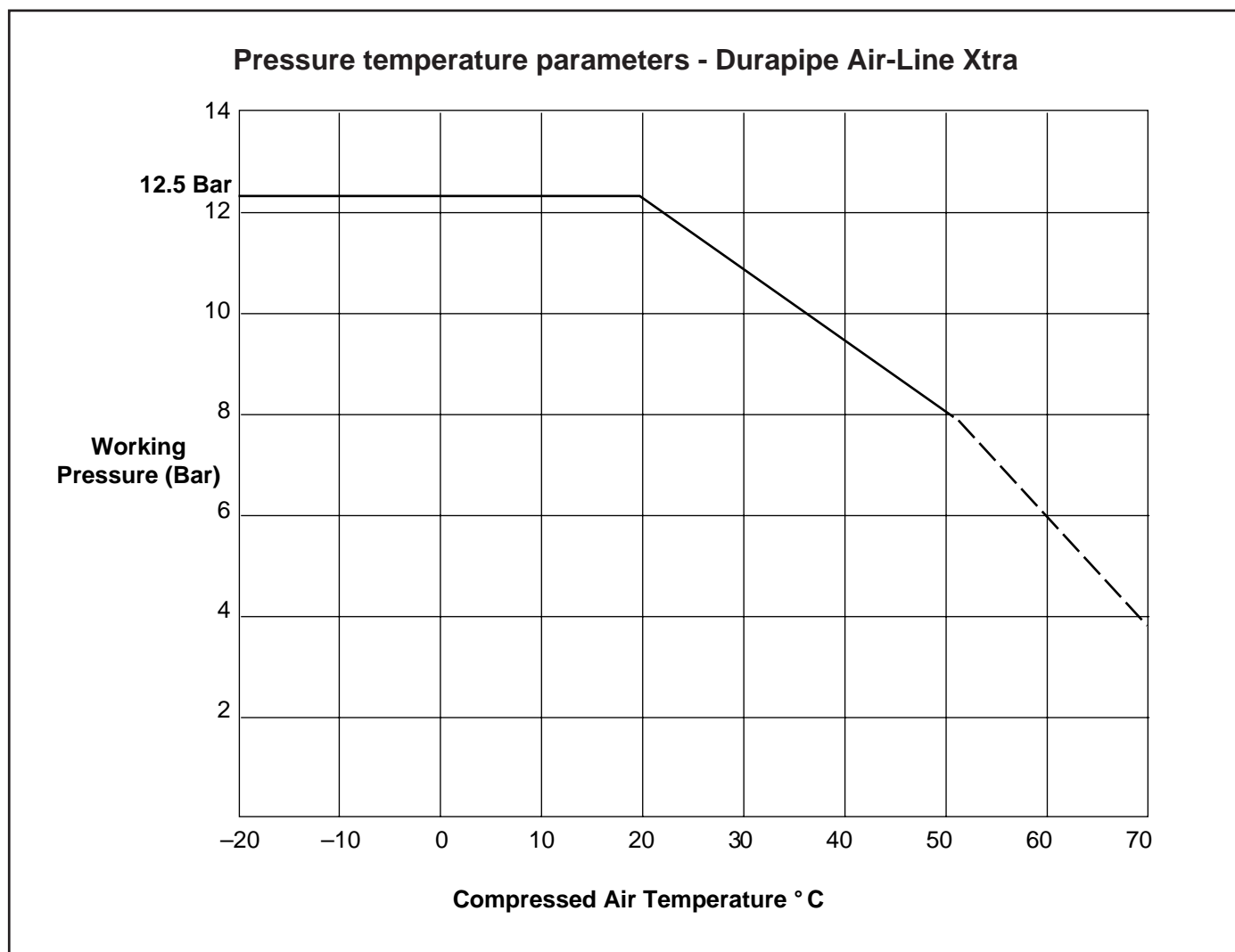

#### NOTES:

1. Graphs are based on an ambient temperature of 20°C.
2. For higher ambient temperatures decrease the working pressure by 5% for every 10°C above 20°C ambient.

3. Generally Durapipe Air-Line Xtra systems must not be used at temperatures below -20°C or in excess of 50°C. For applications between 50°C and 60°C consult our technical support department on 01543 272321/01543 273165.

## Design and installation

### Durapipe Air-Line Xtra Nomogram – for pressure drop and flow rate in compressed air pipework

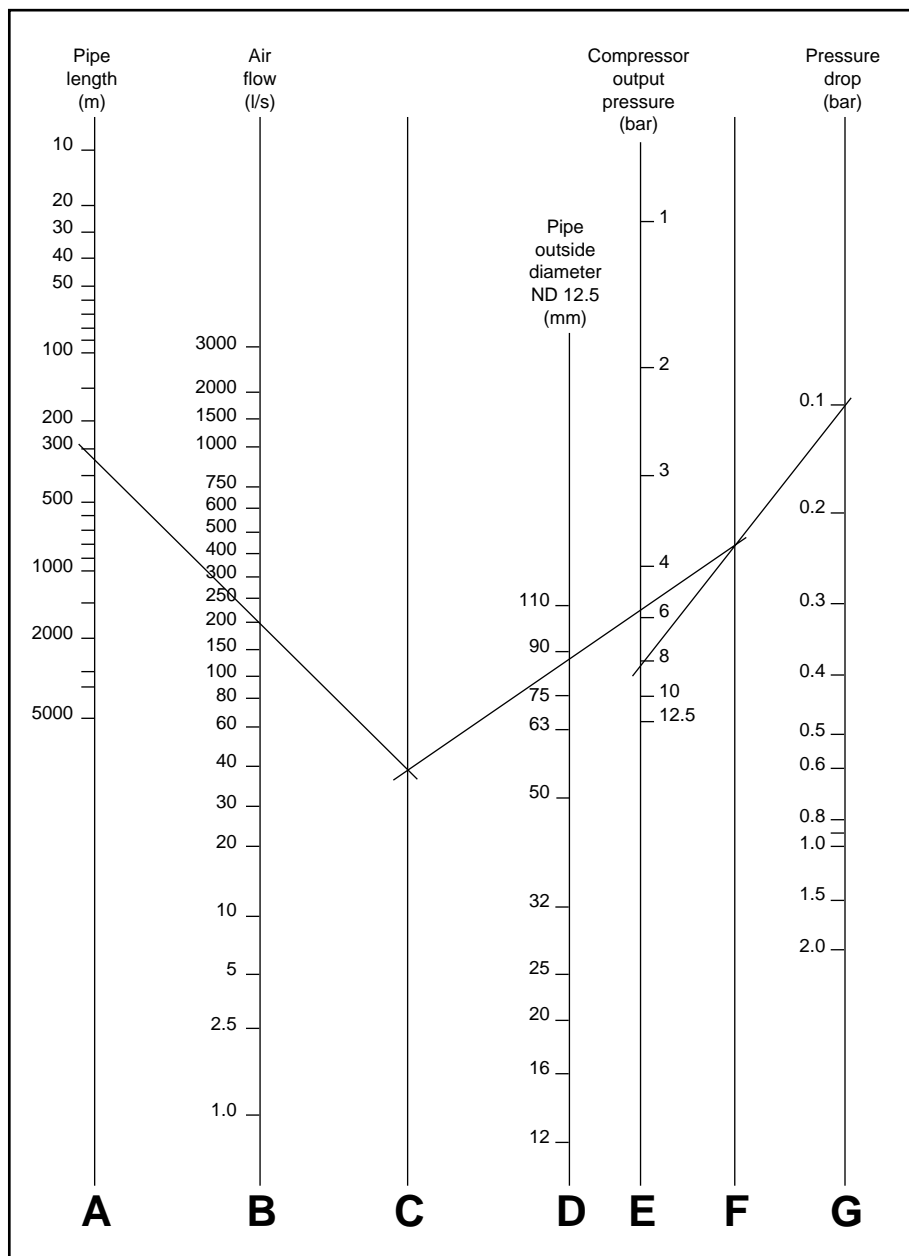

### Durapipe Air-Line Xtra Nomogram

The pressure drop tables published previously have now been replaced by a nomogram based on the Standard Isothermal Compressible flow formula and designed to give a quick and easy read off situation. The nomogram is not intended to give absolutely precise information, however it does provide an acceptable means of determining pipe sizes which are sufficiently accurate for the majority of industrial systems.

A worked example is shown with the values being plotted on the small nomogram to illustrate its correct use.

Copies of an A4 size nomogram are available upon request, for use in determining your own system requirements.

#### How to use the Nomogram

##### Example:

What size of pipe will be required for a system 300m long, comprising of fittings with a pressure drop equivalent to a 20m length of pipe.

The compressed air is required to drive air tools and equipment with a total air consumption of 200 l/s. The minimum pressure required i.e. of the furthest point is 7 bar. A compressor rated at 8 bar and 250 l/s has been chosen.

The pipework should be sized for an anticipated future demand of 250 l/s.

Therefore:  
 $L = 300 + 20 = 320\text{m}$   
 $Q = 250\text{ l/s}$   
 $P = 8\text{ bar}$   
 $\delta$  is chosen to be = 0.1 bar

The length of the pipework run is plotted on scale 'A' (320m) and flow rate on 'B' (250 l/s). A straight line is drawn to connect 'A' to 'B' and extended to 'C'.

The compressor output pressure (8 bar) is now plotted on scale 'E' and the acceptable pressure drop  $\delta$  (0.1 bar) is plotted on 'G'. Again a straight line is drawn to connect 'E' to 'G' which cuts through 'F'.

The intersection points on 'C' and 'F' are now connected with a straight line. The intersection of this line through scale 'D' gives a minimum pipe size. In the example the line 'C' to 'F' cuts 'D' at just under 90mm. 'D' is scaled in standard pipe sizes and therefore the minimum suitable pipe size will be that shown immediately above the intersection i.e. 90mm.

## Design and installation

### Pipe sizing

The compressed air mains are the all-important link between the compressor and the point of usage. Correct sizing of the pipework system for both current and future demand is therefore essential to maximise the cost-effectiveness of the system. Pipework pressure drops are unrecoverable, waste energy and should be kept to an absolute minimum.

Mains which are too small will also cause high air velocity, thus making it difficult to separate the water from the air (since much of the condensed vapour running as water along the

bottom of the pipe will be whipped up by, and carried along with, the fast moving air stream).

For the main distribution line from the compressor, excessive pressure drops and energy loss can be avoided by restricting air velocity to a maximum of 6m/s, (1200ft/min). Higher velocities can be permitted in the shorter service lines. The use of larger pipe sizes is often advantageous, as it can act as a reservoir or receiver for the air thus reducing the load on the compressor and providing capacity for increased future demand.

In order to determine the correct pipe size for a particular length of main, the following information is required.

- a Total length of pipework, L(m)
- b Volumetric flow rate of air, Q(l/s)
- c Pressure output of compressor, P(bar)
- d Allowable pressure drop in the system,  $\delta P$ (bar)

Ideally the total system pressure drop should not exceed 0.3 (bar) (BCAS figure). However a drop slightly in excess of this can usually be tolerated.

### Maximum Recommended flow rates – PN12.5 Durapipe Air-Line Xtra pipe

Applied pressure (bar)	0.5	1	1.5	2	4	6	8	10	12.5
Pipe O/Dia. (mm)	Maximum recommended air flow - L/sec (flow velocity < 6 m/s)								
16	1.05	1.4	1.75	2.1	3.51	4.91	6.31	7.72	9.47
20	1.76	2.35	2.94	3.53	5.88	8.24	10.59	12.94	15.88
25	2.88	3.85	4.81	5.77	9.62	13.46	17.31	21.16	25.96
32	4.85	6.47	8.09	9.71	16.18	22.65	29.12	35.59	43.68
40	7.61	10.14	12.68	15.21	25.35	35.5	45.64	55.78	68.45
50	11.83	15.77	19.71	23.65	39.42	55.19	70.96	86.73	106.44
63	18.82	25.1	31.37	37.65	62.75	87.85	112.94	138.04	169.42
75	26.74	35.65	44.57	53.48	89.13	124.79	160.44	196.09	240.66
90	38.4	51.2	64	76.8	128.01	179.21	230.41	281.61	345.61
110	57.52	76.69	95.87	115.04	191.74	268.43	345.13	421.82	517.69

Examples of maximum recommended air flow rates for various sizes of Durapipe Air-Line Xtra pipe and air pressures are given in the tables opposite. These are based on a maximum flow velocity of 6 metres per second.

E.g. a compressor delivering 340 litres/sec at 12.5 bar would require a 90mm o/dia Durapipe Air-Line Xtra pipe (actual maximum capacity would be 345.61 litres/sec).

### Pressure drops – fittings

Pressure drop does not only occur in the pipe but also in fittings, valves and filters. Therefore the total is the

summation of all the individual pressure drops for valves, filters and other ancillary equipment. For pressure drops

across valves, filters and other ancillary equipment refer to the particular manufacturer's literature.

### Pressure drop – Equivalent pipe length in metres

Fitting type	Pipe outside diameter – mm									
	16	20	25	32	40	50	63	75	90	110
90° elbow	1.96	1.26	1.22	1.15	1.11	1.07	1.08	1.09	1.10	1.11
45° elbow	1.26	0.90	0.68	0.46	0.45	0.43	0.40	0.48	0.57	0.69
90° bend	0.85	0.61	0.59	0.49	0.47	0.44	0.42	0.43	0.51	0.59
Tee in line flow	0.87	0.38	0.26	0.29	0.28	0.29	0.23	0.11	0.10	0.15
Tee in line to branch flow	2.45	1.95	1.52	1.44	1.32	1.18	1.06	1.10	1.19	1.32
Reducer	2.04	1.42	1.35	1.29	1.27	1.25	1.28	1.33	1.39	1.45
180° dropper bend	0.36	0.39	0.37	0.36	—	—	—	—	—	—
Composite unions	0.91	0.47	0.41	0.36	0.34	0.31	0.28	—	—	—

## Design and installation

### Installation Techniques

Thermoplastics and metals have very different physical and mechanical properties. It is essential therefore that products manufactured from these materials are installed in a manner best suited to the material in question.

Thermoplastic pipes for instance, have a higher thermal expansion rate and greater flexibility than metals. However, by correct supporting and routing the increased flexibility can be used to accommodate any increase in thermal movement.

Installation techniques specific to thermoplastics therefore need to be employed to ensure the efficient operation of the resulting system. Guide-lines with respect to Durapipe Air-Line Xtra are detailed in the following pages.

### Pipe supports

#### Support Centres

The following support centres are recommended for Durapipe Air-Line Xtra pipes. These should not be exceeded in horizontal lines, otherwise long term sagging between supports may result. For vertical pipes, the support centres shown can be increased by 50%.

### Durapipe Air-Line Xtra pipe support centres

Outside dia (mm)	Support spacing (m)	
	20°C	
16	1.1	For each 10°C temperature rise reduce support spacing by 10%
20	1.2	
25	1.4	
32	1.5	
40	1.7	
50	1.9	
63	2.1	
75	2.3	
90	2.5	
110	2.8	

#### Support Design

Durapipe Air-Line Xtra pipes are light in weight, (approximately 1/8th the weight of steel), which means that the system supports can be of light construction.

If subject to temperature changes, Durapipe Air-Line Xtra will expand more than metal. This expansion should be controlled by laterally constraining the pipes whilst allowing free axial movement. Thus pipe supports should:

1. Be rigid in construction – To adequately support the pipe (fabricated mild steel angle is ideal).
2. Have a wide bearing area – To allow free transmission of pipe movement and to avoid localised stressing.
3. Be free from sharp burrs or edges – To avoid cutting into the pipe wall.
4. Allow free axial pipe movement – To avoid pipe snaking.
5. Provide lateral restraint – To avoid pipe snaking.

Durapipe Cobra pipe clips should be used with Durapipe Air-Line Xtra. These allow free axial pipe movement and afford lateral restraint (A).

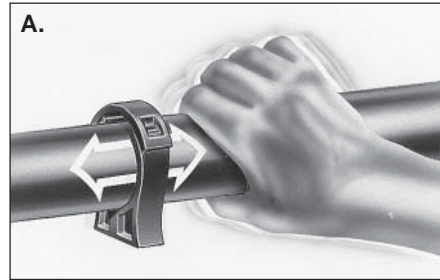

#### Support design

The diagrams illustrate the types of support that are ideally suited to the Durapipe Air-Line Xtra system (B). Support fixings can be via rawlbolts, set pins, lindaptors etc. as appropriate.

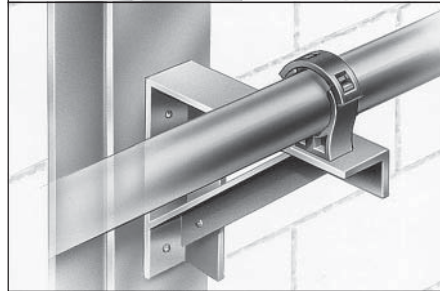

Long hanger rod type supports are not designed to provide lateral restraint to pipework and hence are not recommended for use with Durapipe Air-Line Xtra systems where significant expansion is expected since pipe snaking may result (C).

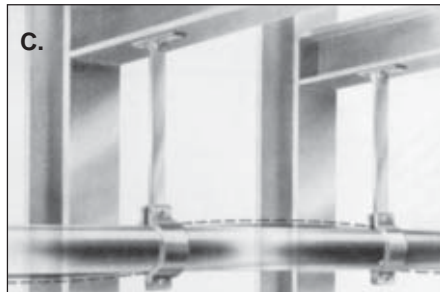

The illustration shows 110mm pipe.

However, if it is not practical to support by any other method hanger rods can be used with rigid supports (C). In this case, hanger rods should be kept as short and rigid as possible and also must allow free axial pipe movement.

### Support of heavy equipment

Large valves, filters and other equipment should always be independently supported and anchored to prevent undue loading and stress being transmitted onto the Durapipe Air-Line Xtra system. Valve support plates can be used in place of flange backing rings to satisfy this requirement (D).

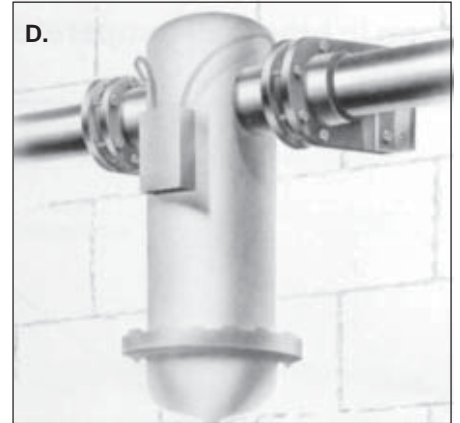

For smaller valves and equipment, two pipe clips situated immediately adjacent to either side of the equipment will prevent transmission of excess torque and other loadings to the Durapipe Air-Line Xtra pipe (E).



### Thermal expansion

#### Expansion rates

Whilst thermoplastics expand more than metals, they have a much lower thermal conductivity. This means that the entire wall of a plastic pipe does not reach the same temperature as the contents, unless the pipe is wholly immersed at the same temperature inside and out.

The expansion and contraction of a plastic pipe is a function of the change in average temperature of the pipe wall.

This means that the expansion in a thermoplastic pipe is frequently less than expected because the average pipe wall temperature is lower than the contents.

Durapipe Air-Line Xtra has a coefficient of expansion of  $10.1 \times 10^{-5}$  per °C compared with  $2 \times 10^{-5}$  and  $1.2 \times 10^{-5}$  for copper and steel respectively.

Approximate expansion rates for Durapipe Air-Line Xtra pipes are shown on the graph at the top of page 9.

More precise information can be obtained from the formula given on page 11.

## Design and installation

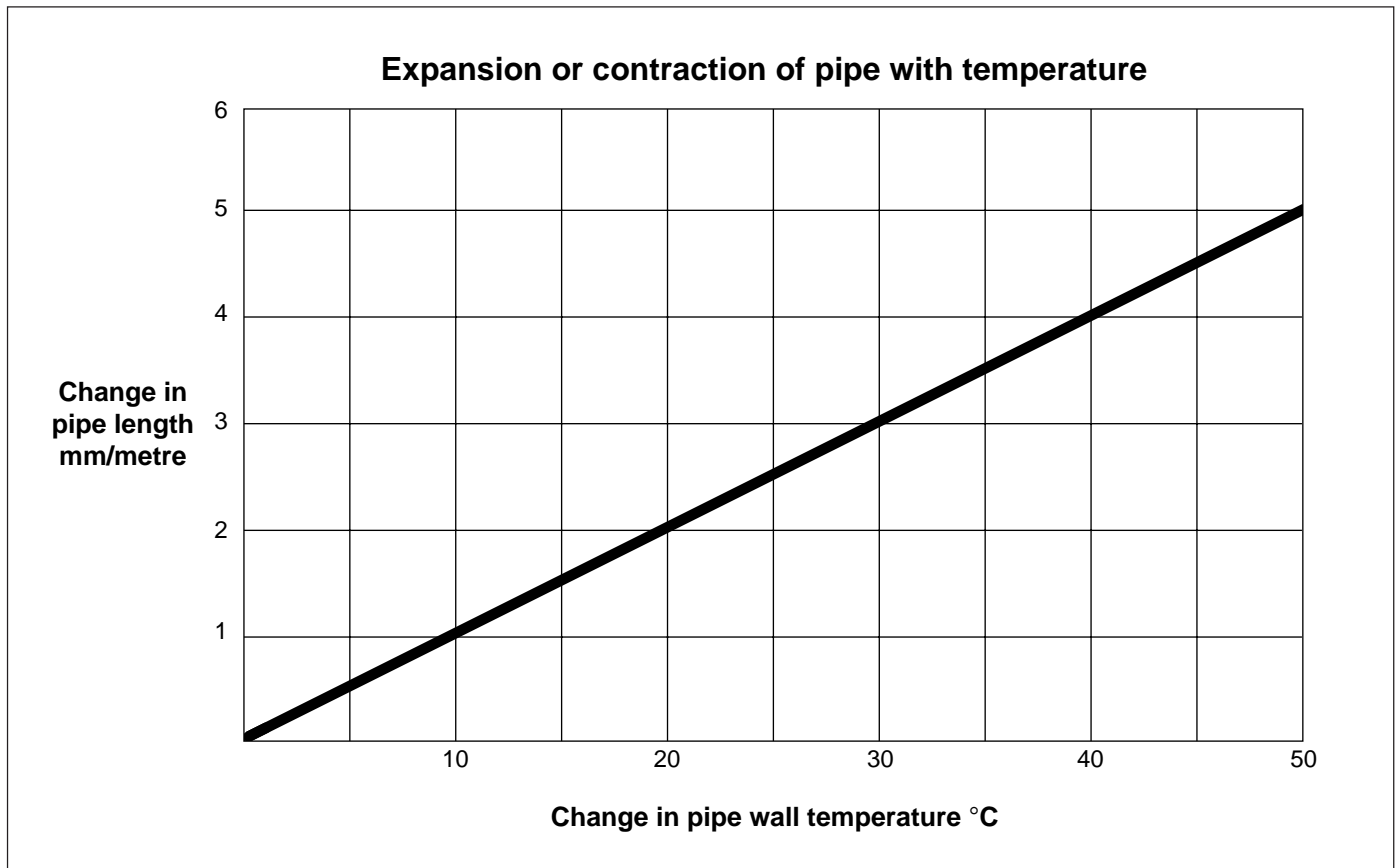

Because of the small differences between ambient and service air temperatures, plus the low thermal conductivity of the Durapipe Air-Line Xtra material, any pipe expansion can usually be accommodated by utilising the natural flexibility of the product and by careful pipe routing.

The basic principle of design is to allow pipe runs to move axially from a fixed point and then to guide this movement into a change of pipe direction ensuring that the pipe is free to flex as shown in Fig 1.

The following examples explain this principle in further detail.

### Pipes constrained at both ends (Fig 2)

In the diagram, the pipe run is fixed at one end to the flanged outlet of the air receiver, (Point A), and constrained at the other end by virtue of its close proximity to the wall, (Point B).

As the temperature increases, the pipe will try to expand outwards but will have nowhere to go because of its fixed ends. Thus, the pipe will snake between supports, as indicated.

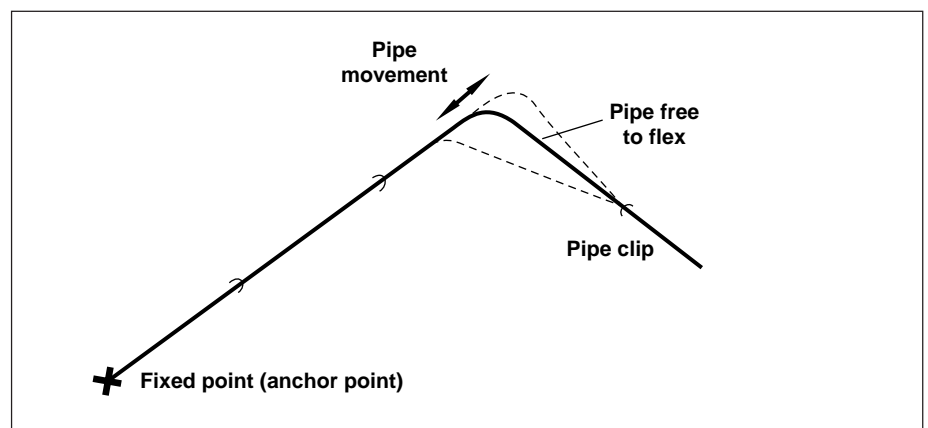

Fig 1

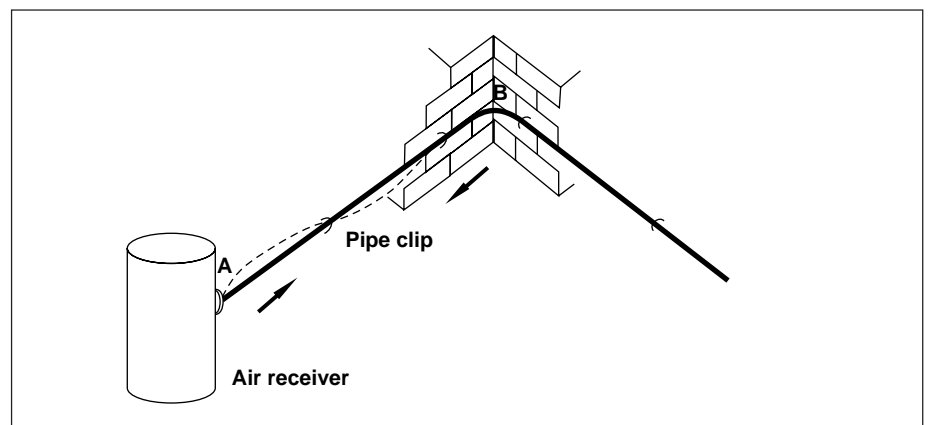

Fig 2

## Design and installation

### Pipes constrained at both ends – Solution (Fig 3)

By utilising fabricated angle iron brackets and Cobra pipe clips along pipe length, B, D, the pipe can be installed away from the wall with sufficient room for the pipe to expand and contract.

Now the pipe will expand away from its fixed point, (the air receiver – A), and the movement will be guided into the change of direction, i.e. pipe leg length B, D.

n.b. The support at C remains but the clip is removed to give sufficient leg length for flexibility.

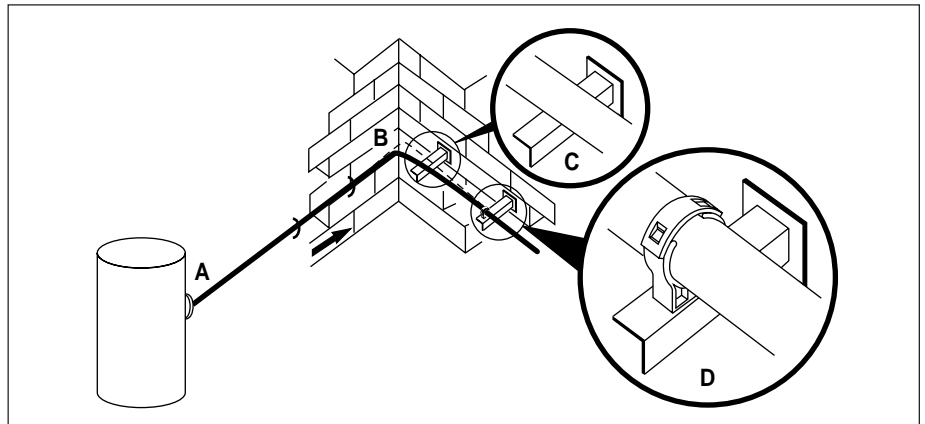

Fig 3

### Pipe anchors (Fig 4)

In the previous example, the air receiver acted as an anchor point to the pipe system and this served to direct the thermal expansion of the pipe – i.e. the pipe was forced to move in one direction from Point A.

Equipment such as valves, filters and lubricators may need independently supporting, as previously indicated (page 8). These supports will automatically serve as anchors to the system.

Where natural anchors do not exist pipe movement should be controlled by constructing anchor points.

Typical methods are shown in Figs 4a and 4b. It should be noted that under no circumstances must the pipe be physically gripped or compressed – simply restrained from moving.

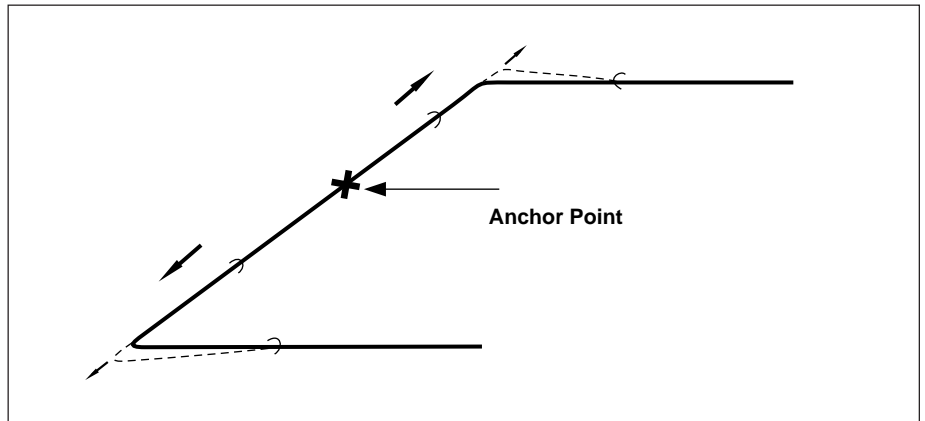

Fig 4

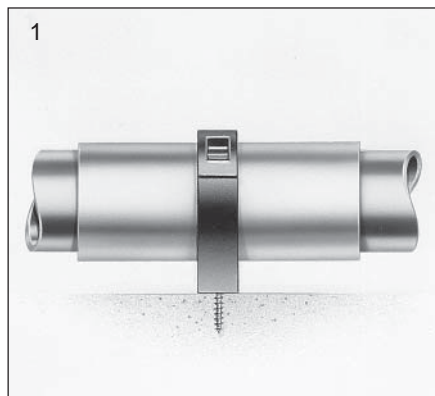

Fig 4a

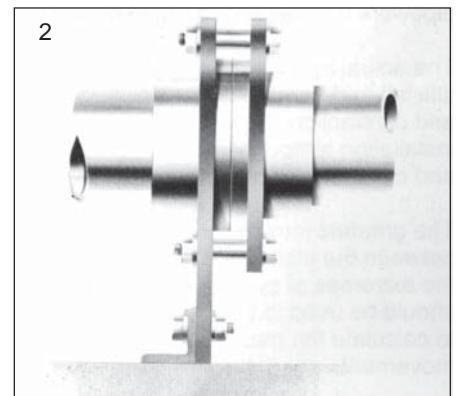

Fig 4b



## Design and installation

### Pipe flexibility

It is essential that the pipe leg (H in Fig 7) into which expansion is being directed is flexible enough to accommodate the expected movement. In certain cases leg lengths may need to be increased. Where insufficient flexibility exists then expansion loops may be required (see Fig 8).

Fig. 9 illustrates these principles in system layout. The pipe (A) will be liable to excessive force generation since no allowance for movement is made. However in the case of pipe (B) the pipe loop allows for the take-up of movement.

Independent of the type of supports, all support surfaces offer frictional resistance to the movement of pipe. This resistance is cumulative and in order to prevent it exceeding the buckling load of the pipe, provision for expansion should be incorporated at intervals not exceeding 40m.

The degree of flexibility required in pipe legs is dependent upon the amount of pipe expansion to be accommodated. Typical calculations are detailed on page 13.

### Flexibility – sizing of leg lengths and loops

The actual expansion or contraction of Durapipe Air-Line Xtra pipe is dependent on the change in temperature of the mid wall of the pipe. The mid wall temperature is dependent on the internal and external environmental temperature with the temperature of the flowing media having the greater influence, unless the pipework is subjected to radiated heat.

The actual mid wall temperature can be difficult to determine. Expansion and contraction is therefore calculated using the installation temperature and maximum and minimum system temperatures.

The greatest temperature difference ( $\Delta T$ ) between the installation temperature and the extremes of system temperature should be used in the following equation to calculate the maximum thermal movement.

$$\Delta L = L \alpha \Delta T$$

Where:  $\Delta L$  = Change in length of pipework section under consideration in metres  
 L = Original length of pipe in metres  
 $\alpha$  = Coefficient of linear expansion of pipe material in  $m/m^{\circ}C$   
 $\Delta T$  = change in pipe temperature

For Air-Line Xtra  $\alpha = 10.1 \times 10^{-5}$  per $^{\circ}C$

The resulting value of expansion can then be entered onto the graph opposite and the appropriate leg length, or loop size, read directly from the graph.

### Configurations to accommodate expansion

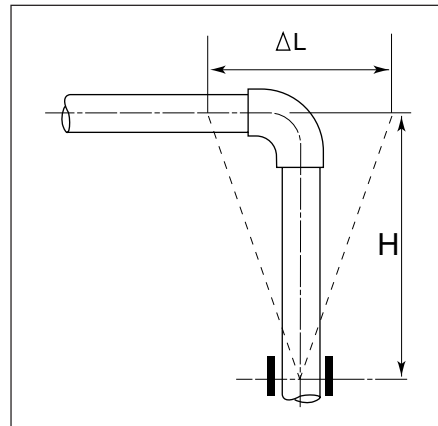

Fig 7

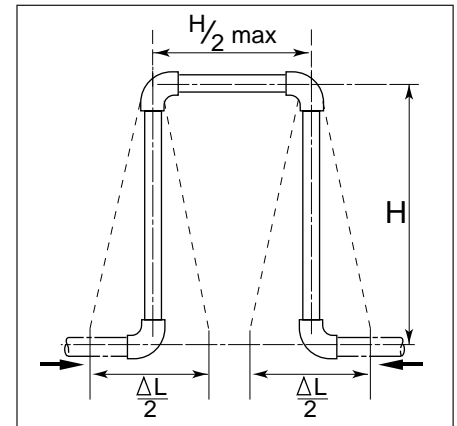

Fig 8

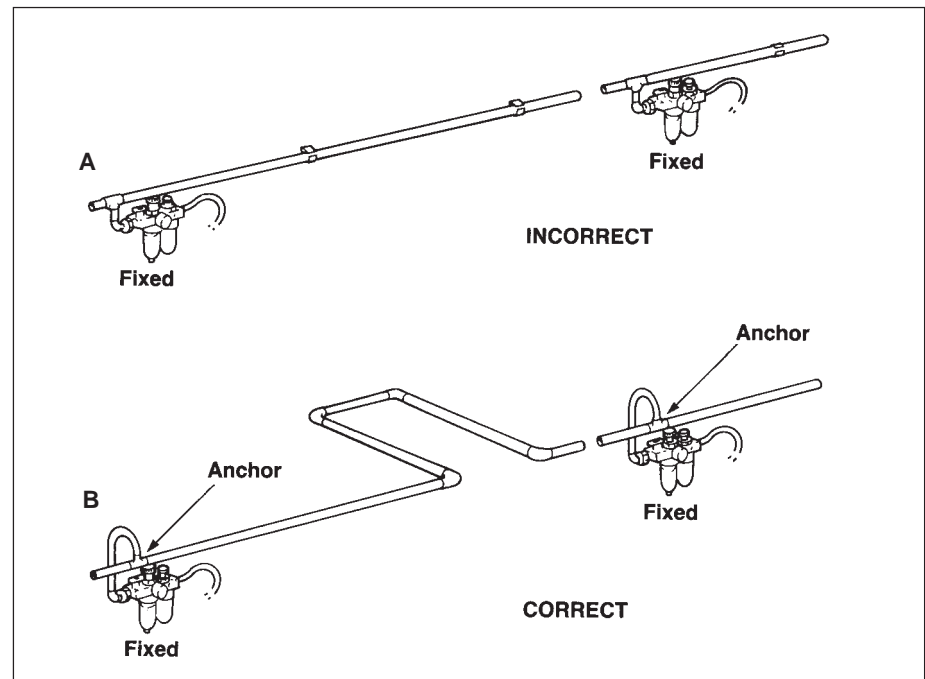
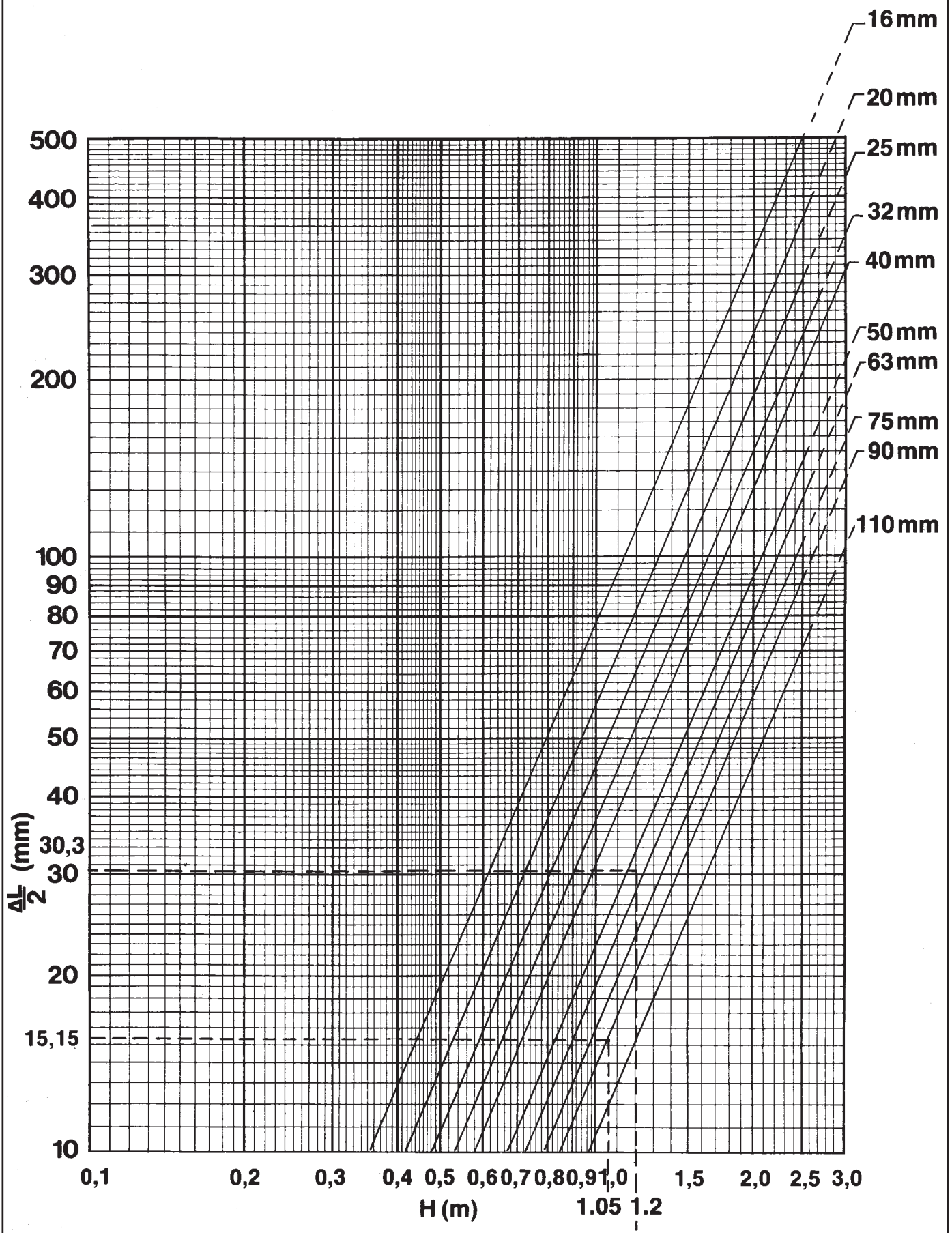

Fig 9

Fig 9



## Design and installation

### Example 1: Leg length

The 90mm Durapipe Air-Line Xtra pipe shown in (Fig 10) is conveying the compressed air at a temperature varying between 20°C and 40°C. The installation temperature is 25°C. Determine the free leg length required at the change of direction to accommodate thermal expansion.

#### Solution:

$$\Delta T_1 = (40-25) = 15^\circ\text{C expansion}$$

AND

$$\Delta T_2 = (25-20) = 5^\circ\text{C contraction}$$

Using the greater value  $\Delta T_1$ , the pipe expansion can be calculated.

$$\Delta L = L \alpha \Delta T_1$$

$$\therefore \Delta L = (10 \times 10^3) (10.1 \times 10^{-5}) (15)$$

i.e.  $\Delta L = 15.15\text{mm}$

#### Calculate leg length A-B

Using the value of 15.15mm draw a horizontal line on the graph (page 12) from the vertical scale to meet the 90mm pipe gradient line. Drop a perpendicular from the intersection point, to the horizontal scale. The figure obtained is the leg length required, i.e. length A to B.

In this case therefore, the leg length will be 1.05 metres, i.e. the first support guide should be positioned at B, 1.05 metres from the elbow at A.

Note:

A support without a guide will be required at point A.

### Example 2: Expansion loops

Determine the loop size required in a 63mm Durapipe Air-Line Xtra pipe which is constrained at both ends as shown in (Fig 11). The compressed air temperature varies between 5°C and 50°C. The installation temperature is 20°C, but in the winter shut down period the temperature can drop to 0°C.

#### Solution:

The solution follows exactly the same principles followed in the previous example.

$$\Delta T = (50-20) = 30^\circ\text{C expansion}$$

AND

$$\Delta T = (20-0) = 20^\circ\text{C contraction}$$

$$\Delta L = L \alpha \Delta T$$

$$\therefore \Delta L = (20 \times 10^3) (10.1 \times 10^{-5}) (30)$$

i.e.  $\Delta L = 60.6\text{mm}$

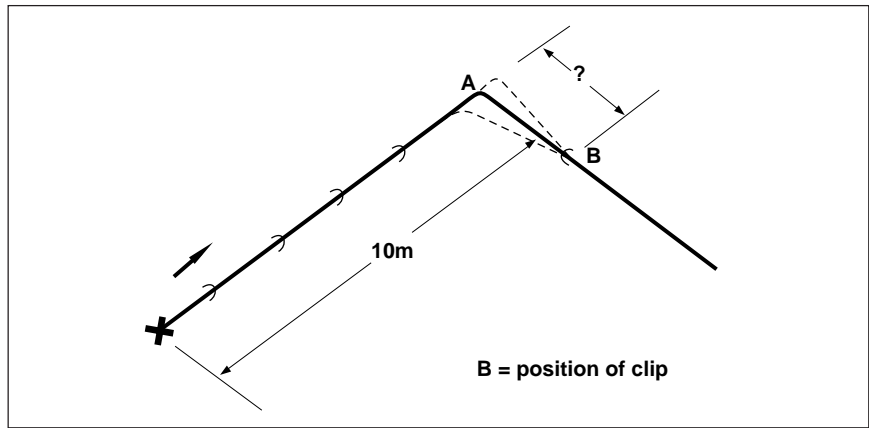

Fig 10

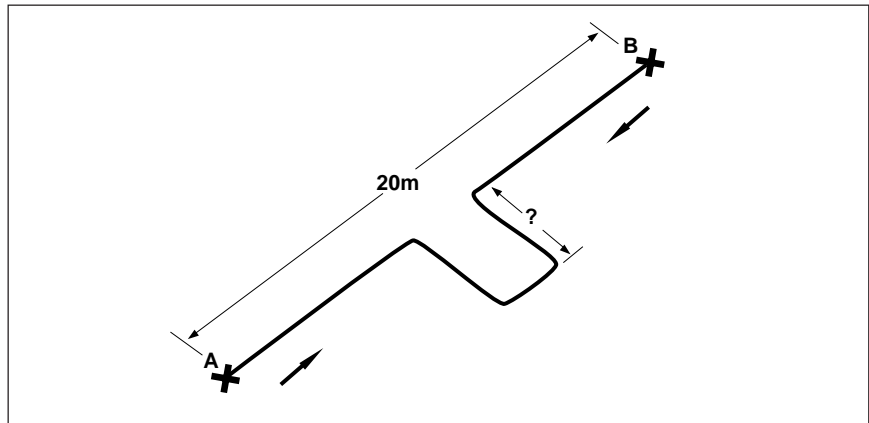
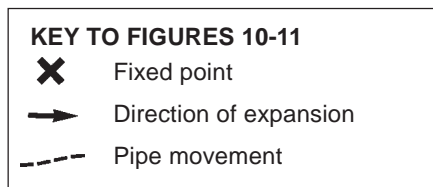

Fig 11

#### Calculate loop size

In this case the expansion is equally split and is directed inwards from points A and B. Therefore, using a value of  $\Delta L/2$  (i.e. 30.3mm) draw a horizontal line on the graph from the vertical scale to meet the 63mm pipe gradient line. Drop a perpendicular from the intersection point to the horizontal scale. The figure obtained is the leg length of loop offset required, i.e. 1.2mm.



## Design and installation

### Buried pipes

Durapipe Air-Line Xtra is equally suited to above ground and buried use.

Recommendations covering essential requirements for large runs below ground may be summarised as follows:

In general, trenches should not be less than 1 metre deep. However, site conditions may permit pipes being laid nearer the surface and the Technical Support Department should be contacted for detailed advice.

Trenches should be straight sided and as narrow as practicable to allow proper consolidation of packing materials.

Trench bottoms should be as level as practicable.

Large pieces of rock, debris and sharp objects should be removed.

Unless the excavation is in ground of friable, small and regular material, a bed of finely graded gravel should be laid (9mm or similar) approximately 75mm deep on floor of trench. (Sand may be used but a high water table may wash sand away and leave the pipe unsupported.)

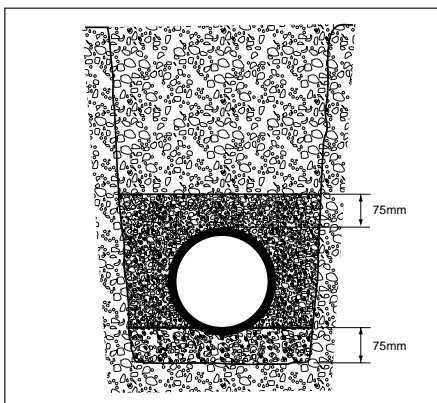

If pipes are jointed above ground, they should remain undisturbed for 2 hours before being 'snaked' into the trench. Alternatively, they may be jointed in the trench.

Particular care should be taken to ensure that pipes and jointing materials are thoroughly dry and that the jointing procedure shown on page 15 is strictly followed.

After laying, pipes should be covered with pea gravel, or similar material, to a depth of 75mm above the pipes and extended sideways to both trench walls. Joints should be left exposed for pressure testing.

Care should be taken to ensure that sharp objects, stones, etc., are prevented from falling into the trench before covering the pipe with pea gravel.

Back filling should be carried out between joints and consolidated prior to pressure testing.

After pressure testing, joints should be covered with pea gravel and back filling completed.

Because of the water vapour which can build in any compressed air system, drain pits should be constructed at the lowest points of the line in order that a drain facility can be incorporated.

### Testing

It is suggested that the following test procedure be followed, after joints have been allowed to dry for the appropriate minimum time.

The system should be divided conveniently into test sections.

Fill the section with cold water making sure that no air pockets remain. Do not pressurise at this stage.

Check the system for leaks. If no leaks are apparent check for and remove any remaining air. Increase pressure up to 50lb/in<sup>2</sup> or 3 bar. Do not pressurise further at this stage.

Leave the section pressurised for 10 minutes. If the pressure decays, inspect for leaks and rectify as necessary. If the pressure remains constant, slowly increase the hydrostatic pressure to 1½ times the nominal operating pressure.

Leave the section pressurised for a period not exceeding 1 hour. During this time the pressure should not change.

## Installation Guide

Jointing of Durapipe Air-Line Xtra pipes and fittings is achieved by means of the cold solvent welding process. Correctly made, the resulting joints are stronger than either pipe or fitting.

Solvent cement welding offers a fast and simple means of constructing leak-free, high intensity pipe joints.

The Durapipe Air-Line Xtra solvent cement is designed and formulated to match the performance of the system. When applied, it will chemically soften the prepared surfaces of pipe and fitting, thus allowing fusion between the mating surfaces to create a homogenous joint when brought together.

Correct, high integrity jointing is dependent upon the removal of all traces of foreign matter from the mating surfaces i.e. oil, dirt grease etc. The cleaner the mating surfaces prior to jointing, the stronger the resulting joint will be.

### The following jointing procedure must be used to achieve maximum joint efficiency.

- 1 The pipe must be cut clean and square. A suitable wheel cutter will eliminate the swarf. Alternatively a carpenter's saw may be used, however this does create dust which may enter the system.
- 2 Deburr pipe end and chamfer the pipe outside diameter using a chamfering tool or file and clean out any swarf or debris created.
- 3 Thoroughly abrade the mating surfaces of both pipe and fitting.
- 4 Clean the abraded surfaces with MEK cleaner using a clean lint free cloth or industrial wipe.
- 5 Stir contents of container.
- 6 Apply the Durapipe Air-Line Xtra solvent cement to the inside of the socket and the outside of the pipe in a rotary motion using the roller applicator provided.
- 7 Immediately after application of the cement, push pipe fully into the fitting. Hold the pipe and the fitting, without twisting, for a few seconds.
- 8 Application of the correct amount of cement will result in a neat bead of the cement forming around the edge of the pipe and fitting. Wipe off any excess cement.
- 9 Replace lids on both the solvent cement and MEK containers to keep the contents clean and minimise solvent evaporation.

### Precautions

Always use clean, lint free cloth or industrial wipes.

Always use genuine Durapipe Air-Line Xtra solvent cement and MEK cleaner.

Always replace lids on containers after use.

Always keep joint surfaces dry.

Never use cement or cleaners in confined spaces without adequate ventilation.

Never joint near naked flames.

Do not smoke in the working area.

Never dilute cement with MEK cleaner.

Solvent cement and cleaners are hazardous, flammable materials and should be stored and handled with care and kept out of the reach of children.

Safety Data Sheets for these products are available.



*Cut pipe*



*Deburr/chamfer*



*Abrade pipe and socket*



*Clean with MEK*



*Stir solvent cement*



*Apply solvent cement to the inside of the fitting*



*Apply solvent cement to the outside of the pipe*



*Push fitting home*



*Wipe off excess solvent cement*

## Number of joints per litre

Under normal conditions the following approximate number of joints can be made per litre of solvent cement. Actual usage will depend upon ambient conditions and fit between pipe and fitting.

16-40mm	:	400 joints
50-63mm	:	110 joints
75-90mm	:	40 joints
110mm	:	25 joints

## Setting Times

Up to 63mm dia. 75mm-110mm

Surrounding temperature	Up to 6 bar	Up to 12.5 bar	Up to 6 bar	Up to 12.5 bar
10°C - 30°C	2 hours	4 hours	4 hours	12 hours
5°C - 10°C	4 hours	6 hours	6 hours	24 hours



## Jointing methods

### Miscellaneous jointing

#### Threaded connections – Durapipe Air-Line Xtra to metal

Connections to metal threads can be readily made using female threaded adaptors, plain/threaded sockets, or composite unions. Durapipe Air-Line Xtra pipes must not be threaded.

PTFE tape wound onto the male thread will effect a good seal between plastic and metal threads (A).

Anaerobic adhesive thread sealants, (eg. Loctite, 542, 572) can chemically attack Durapipe Air-Line Xtra and must not be used.

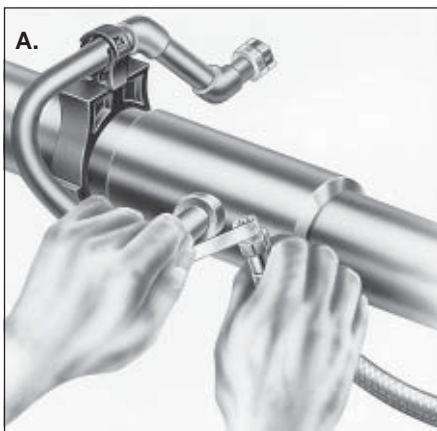

Care should be taken not to overtighten connections. Durapipe Air-Line Xtra threaded fittings should be restrained from twisting during assembly using wrenches if necessary.

Stilsons, or similar wrenches must not be used around Durapipe Air-Line Xtra pipes.

Durapipe Air-Line Xtra should not be connected directly to vibrating machinery. Flexible rubber couplings or rubber hoses should be incorporated to absorb any movement.

#### Connections to Instrumentation

Pressure gauges, temperature gauges and flow measurement (B), probes can be connected into the Durapipe Air-Line Xtra system via female threaded adaptors or composite unions solvent welded into plain Durapipe Air-Line Xtra tees. Heavy items should be independently supported.

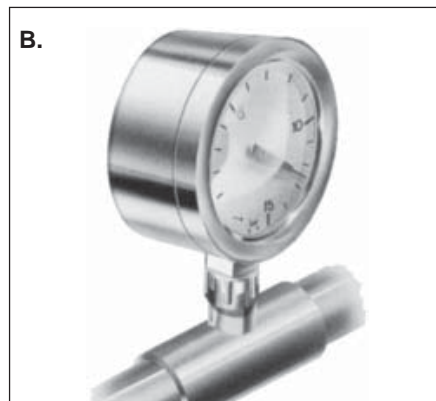

#### Quick release coupling connections

##### High level

Quick release couplings or hoses may be connected into the Durapipe Air-Line Xtra system at high level i.e. (at positions not normally accessible from floor level and not subject to frequent connection and disconnection or dynamic forces) by means of a female threaded adaptor or composite union solvent welded onto a dropper bend.

In this particular case it is recommended that the connection should be reinforced using two pipe clips, as illustrated (C).

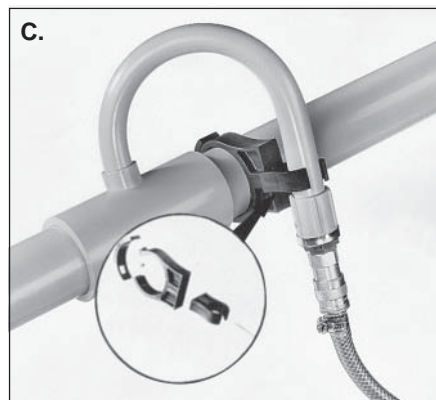

#### Termination of drop legs

It is important that the lower end of all pipe droppers and any take-off points, particularly those employing flexible hoses, are rigidly attached to walls, stanchions etc. Two methods are available for such terminations:

Durapipe Air-Line wall brackets offer this facility and must be used at the lower end of vertical droppers to prevent strain from flexible hoses, when drains are not required.

If drains are to be fitted such that the take-off from the dropper is via a tee piece, then the wall bracket is connected via the branch line as shown below (D).

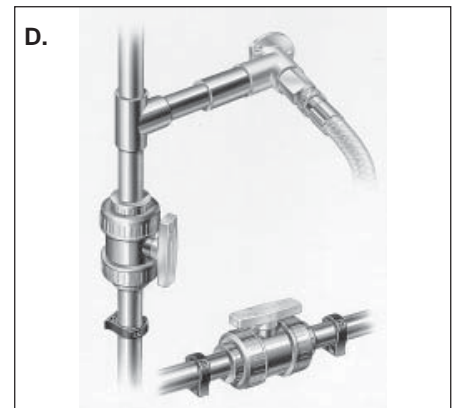

#### Demountable joints

Systems which are required to have a demountable facility can be effected by using Durapipe Air-Line Xtra socket unions or stub flanges. (These can also be used at fixed terminal connections such as air receivers or dryers) (E).

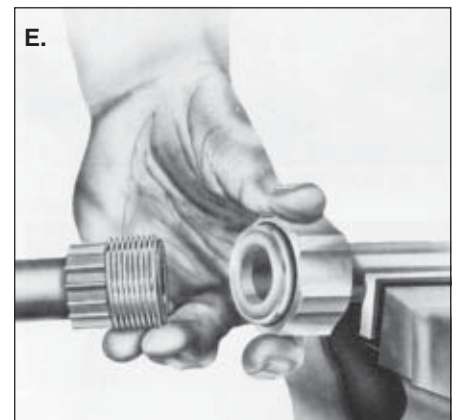



## The Use of Bushes, Reducers and Threaded Adaptors

Example in the use of reducing bushes

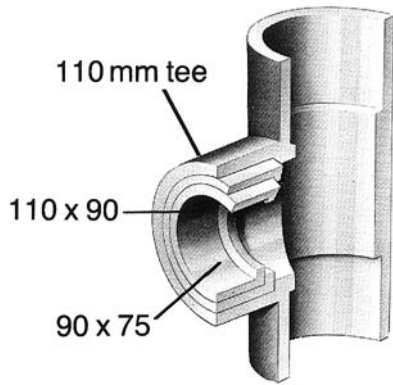

### The use of reducers

All fittings have female ends, dimensionally controlled for cold fusion jointing. In addition the reducers are provided with an additional controlled outside diameter at the large end. They can therefore be used as male or female components as shown.

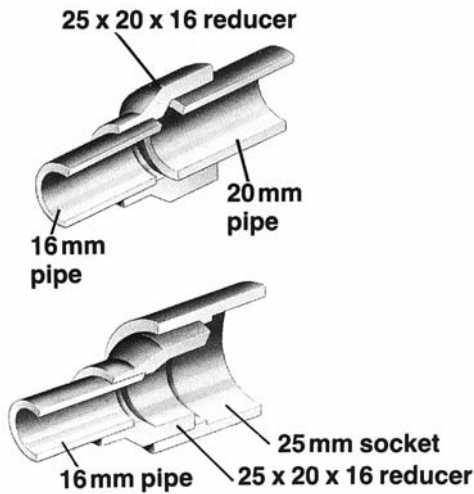

### The use of threaded adaptors

Female and male threaded adaptors have controlled inside and outside diameters on the plain end and can therefore be used as either a male or female component when being solvent cemented to pipe or fittings.

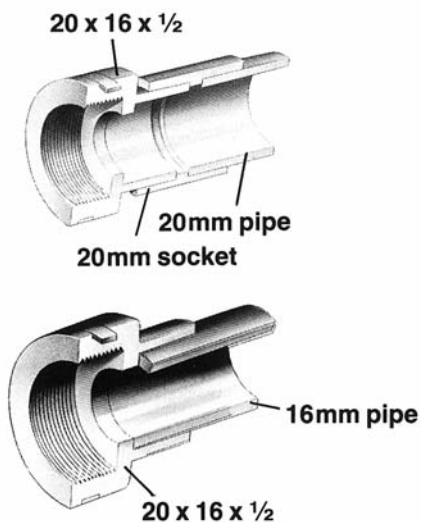

*Female adaptor illustrated as an example*

## Safety precautions



### Areas of use

**Durapipe Air-Line Xtra must be used downstream from the receiver or aftercooler only.**

Care must be taken to avoid overheating Durapipe Air-Line Xtra. Metal pipes must be used between compressor and receiver and at any other part of a system where conditions exceed those permissible for Durapipe Air-Line Xtra. Refer to page 5.

### Installation precautions

Lubricators must only be installed at the downstream extremities of the system.

Durapipe Air-Line Xtra pipes must not be bent. Standard elbows and moulded bends are available throughout the size range.

Certain types of flexible hose contain plasticisers which may be harmful to Durapipe Air-Line Xtra pipe. Therefore the suitability of hoses which are to be installed up-stream of the Durapipe Air-Line Xtra system must be checked with our Technical Support Department prior to installation.

If thermal insulation is required, the suitability of the materials used and any associated adhesives must be confirmed with our Technical Support Department prior to installation.

Purge new compressors and ancillary equipment including new steel pipework prior to connecting to Durapipe Air-Line Xtra pipework.

### Inspection and testing

After installation, the Durapipe Air-Line Xtra system must be inspected for external damage in the form of cuts or deep notches. Any such damaged areas must be cut out and replaced.

The normal precautions for testing a compressed air system before pressurising must be followed for the Durapipe Air-Line Xtra system.

### U.V. light

Care should be taken to avoid prolonged exposure to sunlight, which will cause discolouration of the Air-Line Xtra material. If stored outdoors, products must be underneath an opaque covering, e.g. a tarpaulin. If installed in a location exposed to sunlight, the pipework should be painted.

### Health and Safety at Work Act & COSHH Regulations

Attention is drawn to the requirements in the U.K. of this Act and to the 1988 Control of Substances Hazardous to Health (COSHH) Regulations. Notes on care to be taken in handling and storage of Durapipe *pipelines* products are available in leaflet D0004.

Durapipe *pipelines* cannot accept responsibility for accidents arising from the misuse of its products because of bad installation or incorrect application.

### GENERAL INFORMATION Handling and Storage

The high impact strength of the Durapipe Air-Line Xtra systems provides some protection against damage but care should be taken at all stages of handling, transportation and storage.

Pipe must be transported by a suitable vehicle and properly loaded and unloaded, e.g., wherever possible moved by hand or mechanical lifting equipment. It must not be dragged across the ground.

The storage should be flat, level and free from sharp stones.

### Lengths

Pipe lengths stored individually should be stacked in a pyramid not more than one metre high, with the bottom layer fully restrained by wedges. Where possible, the bottom layer of pipes should be laid on timber battens at one-metre centres. On site, pipes may be laid out individually in strings. (Where appropriate, protective barriers should be placed with adequate warning signs and lamps.)

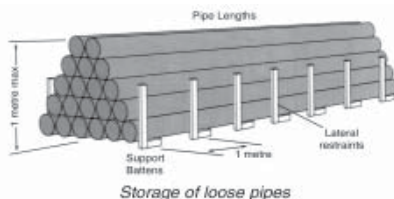

### Bundles

Bundled packs of pipe should be stored on clear, level ground with the battens supported from the outside by timbers or concrete blocks. For safety, bundled packs should not be stacked more than three metres high.

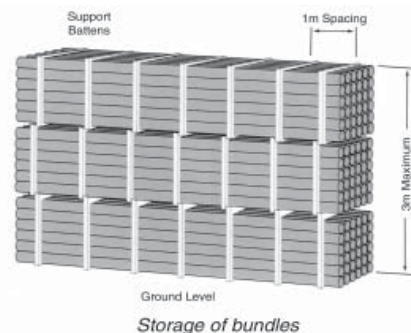

Smaller pipes may be nested inside larger pipes. Side bracing should be provided to prevent stack collapse.

Similar precautions should be taken with fittings and these should be kept in protective wrappings until required for use.

### Weathering

If prolonged storage (greater than 1 month), or storage in areas where high temperature is anticipated, the stack height should never exceed 4 layers or 1 metre maximum height. Such stacks should be protected from the effects of weathering (particularly ultra violet exposure) by placing an opaque covering over them.

If fixed to the side bracing the sheets will provide protected and shaded conditions. It will also allow a free passage of air around the pipes.

### Compressor oils

Synthetic oils must not be used with Durapipe Air-Line Xtra. A few additive rich mineral oils used for compressor lubrication are also incompatible with Durapipe Air-Line Xtra pipework and harmful effects may result in the event of any oil being carried over into the pipework system.

A degree of protection can be achieved by installing oil separators upstream of the Durapipe Air-Line Xtra system; but technical research has shown that even with this safeguard most synthetic oils and certain mineral oils should not be used in conjunction with Durapipe Air-Line Xtra.

As a safeguard therefore, compressor oil suitability **must** be checked with our Technical Support Department prior to installation on 01543 272321/01543 273165.

## Compressor oil suitability

Oils known to be suitable for use in conjunction with Durapipe Air-Line Xtra pipework are as follows. This list must be used in conjunction with compressor manufacturer's recommendations.

It is important that full designation of oil is known e.g. Esso Teresso 46 is not the same as Esso Teresso EP 46

### AGIP

OSO 32, 46, 68, 100  
Dicrea 68, 100, 150  
Acer 46, 68, 100  
OTE 46, 68, 80, 100  
Motor Oil HD 10W/20, 20W/30, 40  
Diesel Sigma S 10W, 20W/20, 30, 40

### AMOCO

ATF Multi-purpose Compressor Oil 260

### AMSOIL

Reciprocating Compressor Oil

### ARAL

Vitam GF (all viscosities)  
Kowal M (all viscosities)  
Kosmol TL (all viscosities)  
Motanol GM 68  
Motanol HE (all viscosities)  
Motanol HK (all viscosities)  
Motanol HP (all viscosities)  
Vitam DE  
Vitam HF (all viscosities)

### ATLANTIC RICHFIELD

Duro 10, 22, 32, 46, 68, 100  
Polar 58  
Gascon 58  
Rubilene 68

### ATLAS COPCO

Roto inject fluid  
Polyalphaolefine Oil

### AVIA

Avilube VD-L 100, 150  
Motor Oil HD 30  
Motor Oil SAE 30

### BATOYLE

Typhon HDT 32, 68, 100  
Renown K 40  
Apollo 32

### BELRAY

SCI 46

### BRENNTAG

Kompressorenol VC-L 68

### BRETTS

Ovoline 660 HD 30  
Ovoline 9032, 9068, 2032, 2068

### BRITISH PETROLEUM

Energol RC-R 32  
Energol THB 32, 46, 68, 77, 100  
Energol HLP 32, 46, 68, 100  
Venellus M 10W, 20W, 30, 40  
Energol IC-D 40  
Energol HP 150  
Energol RC 32, 68, 100  
Vanellus T 40  
Energol SHF 32, 46, 68, 100

### BROOMWADE

4000 Hour

### CASTROL

Aircol PD 32, 68, 100, 150  
Hyspin AWS 22, 32, 46, 68, 100  
Deusol CRI 10, 20, 30, 40  
Agricastrol 10, 20, 30, 40, 50  
Andarin 32, 42, 46  
Perfecto T 32, 46, 68, 100  
Product 672/49  
Magna 32

### CENTURY

ACA  
ACC  
ACD  
ACE  
PWLC  
Turbo 10W  
Compressor Oil B  
Special Medium  
Turbine Oil  
Centlube Supreme 20W/20  
Centraulic AF 68

### CHEMODEX

Zephyr HT 68

### CHEVRON

OC Turbine Oil, 32, 46, 68, 100, 150  
EP Industrial 46, 68, 100  
EP Hydraulic Oil 22, 32, 46, 68, 32 HV, 68 HV  
Delo 200E Motor Oil 10W, 20W/20, 20W/30, 30, 40  
Delo 100, 10W, 30, 40  
Tegra 68  
Tegra FLC 32, 100  
Tegra FLD C 32, 68, 100  
GP Oil 100

### COFRAN

Turbicof  
Cofraline

### CONDAT

Aeropress 32, 46, 68, 100, 150, 320  
Hydrolub ZS 32, 46, 68  
Vicom Special 10W, 20, 30, 40  
Aerospace S100  
Vaseline 2442

### CONOCO

American Industrial 100  
Iso. Vis. Compressor 100  
Super Hydraulic 5W/20 22, 32, 46, 68, 100  
Dectol R & O (all viscosities)  
Turbine 32, 46, 68, 100

### CORROLESS

Anderol R2214

### CPI ENGINEERING SERVICES

CP 4600 32F, 68F  
Comp. Oil 68  
Aeon 4000  
CP4608 68F  
CP9001 32

### DENTON

Compol 30

### DEVILBISS (FRANCE)

Compoil

### DUBOIS

Ultragard 200  
MPO 20

### DUCKHAMS

Deenol 20, 30  
Zodiac 4, 6

### ECUBSOL

KYM  
TWL  
TWM  
Turbo 32

### ELF

Dacnis P 32, 68, 100  
Series 3 Engine Oil  
Sportigrade 15W/30  
Barelf 100  
Olna 32

### EMERY

2819 B  
3006

### ESSO

Teresso 32, 46, 68, 77, 100, 150, 220, 320, 460  
Nuto H 22, 32, 46, 68, 100  
Extra Motor Oil 10W/30, 20W/50  
Plus Motor Oil 10W, 20W/20, 30, 40  
Unifarm 15W/30  
Zerice S 68, 100  
Uniflow 15W/50, 10W/40  
Superlube 10W/40  
Verdichteroel 3020, 3021N, 3022N  
Spinesso 22  
Essolube HDX Plus 10W, 20W/20, 30, 20W/30, 40  
Primol 325  
HLPD 32  
Super Oil 15W/40  
Teresso L-100

### EXXON

Primol 185, 205, 325, 355  
Teresstic 32, 33, 46, 68, 77, 100  
Esstic 32, 68, 150

### FANAL

Salvo VD-L 68, 100, 150

### FILMITE

Filmite 150

### FINA

Bakola (all viscosities)  
Hydran (all viscosities)  
Circan (all viscosities)  
Solco (all viscosities)  
Delta Plus (all viscosities)  
Eolan AC (all viscosities)  
Eolan DCL (all viscosities)

### FREEDOM

Compressor Oil 32, 68  
Hydraulic Oil H27  
Lubace HD 10W

### FUCHS

Renolin B (all viscosities)  
Renolin DTA (all viscosities)  
Renolin 104L  
Renolin MR (all viscosities)  
Renolin 504  
Renolin SC 46  
Renolin SC 46MC  
Renolin 104  
Renolin 102L  
Renolin 106L  
Renolin DT2  
Ratak MN202

**GULF**

Harmony AW (all viscosities)  
Compressor Oil 32, 68, 100  
Hydasil (all viscosities)  
SD 30  
Senate 320-D  
Senate 400-D  
Senate 375  
Senate 680  
Senate 460  
Harmony 22

**HYDROVANE**

2000 Compressor Oil

**INGERSOLL RAND**

Food Grade

**JUN-AIR**

NMI-50

**KERNITE**

Lubra-K-CO  
Lubra-K-RT  
Lubra-K-MPC

**KUWAIT PETROLEUM**

Q8 Verdi 320

**LUBRICATION ENGINEERS**

Monolec GFS

**MARGOLIS**

Silogram MP 157  
Silogram MP 207  
Silogram MP 307  
Silogram MP 507  
Silogram MP 707

**MIHAG**

HS32  
CD46  
CA68

**MOBIL**

Vacuoline 128  
DTE Light  
DTE Medium  
DTE Heavy Medium  
DTE Heavy  
DTE 22, 24, 25, 26  
Rarus 424, 425, 427, 725  
Delvac 1240, 1310, 1110  
HD Oil 100  
ED 62/170  
Almo 527  
Arctic SHC 234  
DTE Extra Heavy  
DTE 13  
DTE 105  
Velocite 6, 10  
ATF Multi-purpose  
Rarus 725  
Mobiland Universal  
DTE 103  
Multigrade 15W/40

**MOLUB-ALLOY**

General Purpose 40

**MOTUL**

CFS-100  
DSM-40  
Safco D

**NEEDWOOD**

Imperial CDX 10, 10W/30

**OMEGA**

Omega 631

**OPTIMOL**

Kompressorenol VD-L 100  
Super HD-30

**PETRO-CANADA**

Super Compressor Oil 32, 68, 100, 150  
Purity FG 32, 46, 68, 100

**SCHAEFFERS**

NO. 158 10W, 20W, 30W, 40W

**SENTINEL LUBRICANTS**

SCO 10, 20, 30, 40

**SERVO-DELLEN (NUODEX)**

Anderol FGC-20  
Anderol RCF-P 46

**SHELL**

Tellus 22, 32, 37, 46, 68, 100  
Corena H 68, 100, 150  
Corena 37  
Tellus T 15, 22, 37, 46, 68, 100  
Tellus S, 32, 37, 46, 68  
Tellus C 32, 68, 100  
Tellus R 37, 46, 68  
Turbo T 32, 46, 68, 100  
Rotella X 20W/40, 10W, 20/20W, 30, 40  
Rimula X 10W, 30, 40, 50, 15W/40  
Rimula 10W, 20/20W, 30, 40, 50  
Talpa 20W, 20, 30, 40, 50, 60  
Comptella 46  
Corena S46  
Talpa G 100  
Corena P 68, 100, 150  
Comptella S46

**SILKOLENE**

Derwent 32, 46, 68  
Trent 32  
Silkair VG22  
Dove 68

**SMALLMAN**

Crownlube A16

**STATOIL**

Compway 32, 46, 68, 100

**SULLAIR**

LLL-4  
24KT  
SRF 1/4000

**SUMMIT**

FG-200  
FG-300

**TEXACO**

Rando 32, 46, 68, 150  
Rando HD 32, 46, 68  
Ursa P 32, 68, 100, 150, 200, 220  
Ursatex 10W, 20W/20, 30, 40  
Compressor Oil VD-L 46, 100, 150  
Compressor Oil VW 460  
Regal R-O 32, 46, 68, 100, 150  
Havoline All Temp. 15W/40  
Texamatic 9226  
Auriga EP46  
Havoline Motor Oil 15W/40  
Rando HD Z 32  
Capella WF 22, 100  
Cepheus 68  
Sera 5

**TOTAL**

Cortusa 32, 68, 100, 150  
Azolla 10, 22, 32, 46, 68, 100  
Cortis EP 46, 100, 150  
HD3C 10W  
Rubia H 10W  
Preslia 46

**ULTRACHEM**

Chemlube 530

**UNOCAL**

Guardol 15W-40

**VALVOLINE**

ETC 30  
Turbinol 2S, 3S  
ETC Light  
Ultramax 32  
Motor Oil 30W

**WINTERSHALL**

Wiolan WT 46

**WITCO**

RDN 654  
RDN 130  
RDN 130R











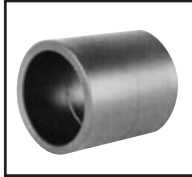

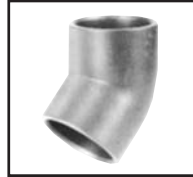





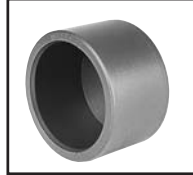









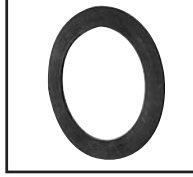

**ZELLER & GMELLIN**

Divinol Spezial 2000 HD 30  
Kompressorenol ZET-GE

Should you have any queries regarding compressor oils please contact our Technical Support Department on 01543 272321/273165.

### Product range dimensions

System available in 16, 20, 25, 32, 40, 50, 63, 75, 90, 110 sizes – designated by outside diameter

 <p>Pipe</p>					
page 22	page 22	page 22	page 23	page 23	page 23
					
page 23	page 24	page 24	page 24	page 25	page 25
					
page 25	page 25	page 26	page 26	page 26	page 26
					
page 27	page 27	page 27	page 27	page 28	page 28
					
page 28	page 29	page 29	page 29	page 30	page 30
					
page 30	page 31	page 31	page 31		



## Pipe PN 12,5

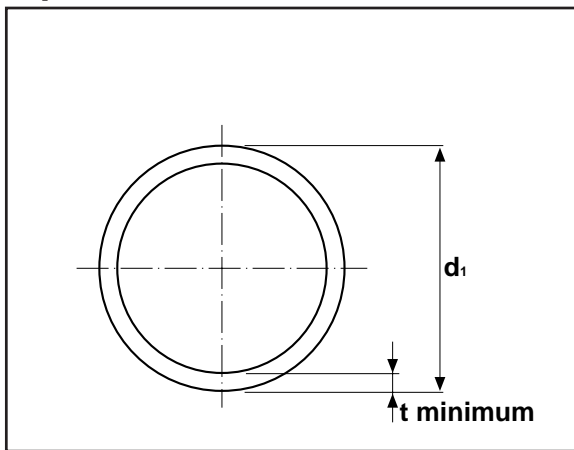

d <sub>1</sub> Size	t	kg/m	SL	Code
16	1.9	0.10	5	31 557 305
20	2.1	0.13	5	31 557 306
25	2.4	0.18	5	31 557 307
32	2.9	0.28	5	31 557 308
40	3.6	0.46	5	31 557 309
50	4.5	0.69	5	31 557 310
63	5.7	1.09	5	31 557 311
75	6.7	1.54	5	31 557 312
90	8.0	2.23	5	31 557 313
110	9.9	3.31	5	31 557 314

## Sockets

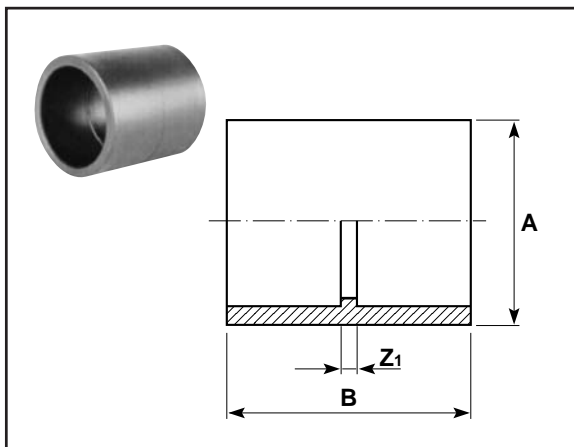

Size	A	B	Z <sub>1</sub>	gms	Code
16	21	31	3	5	31 100 305
20	25	36	3	7	31 100 306
25	31	41	3	12	31 100 307
32	40	48	3	25	31 100 308
40	50	58	3	45	31 100 309
50	62	68	3	77	31 100 310
63	78	81	3	154	31 100 311
75	93	93	3	230	31 100 312
90	111	110	4	380	31 100 313
110	136	132	6	690	31 100 314

## Reducing bushes

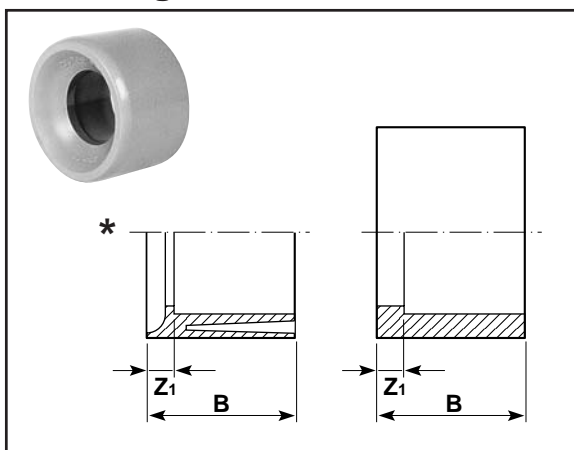

Size	B	Z <sub>1</sub>	gms	Code
20- 16	17	3	2	31 109 412
25- 20	19	3	4	31 109 415
32- 16	23	9	5	31 109 417
32- 25	23	4	6	31 109 419
40- 32	27	5	13	31 109 423
50- 20*	32	16	32	31 109 424
50- 25*	32	13	29	31 109 425
50- 32	32	10	19	31 109 426
50- 40	32	5	25	31 109 427
63- 25*	38	19	60	31 109 429
63- 32*	39	16	36	31 109 430
63- 50	39	7	47	31 109 432
75- 63	45	7	65	31 109 438
90- 50*	53	7	200	31 109 442
90- 63*	54	15	224	31 109 443
90- 75	54	8	110	31 109 444
110- 63*	64	25	252	31 109 449
110- 90	64	10	200	31 109 451

\*Configuration shown in inset.

For an example in the use of reducing bushes see page 17.



**Reducers**

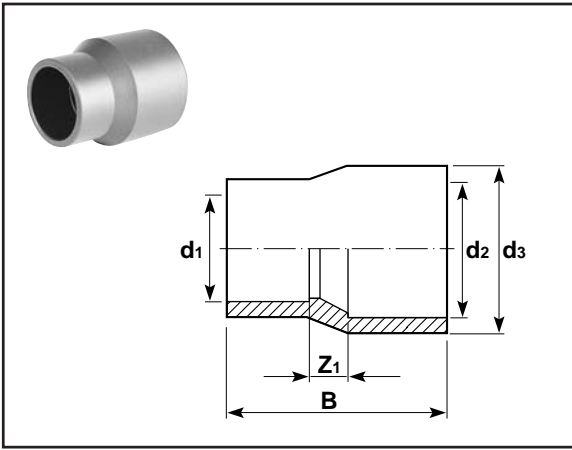

d <sub>3</sub> - d <sub>2</sub> - d <sub>1</sub>	B	Z <sub>1</sub>	gms	Code
25- 20- 16	37	6	6	31 114 412
32- 25- 20	42	6	12	31 114 415
40- 32- 25	50	8	22	31 114 419
50- 40- 32	60	10	39	31 114 423
63- 50- 40	71	12	80	31 114 427
75- 63- 50	85	14	108	31 114 432
90- 75- 63	97	13	190	31 114 438
110- 90- 75	114	15	350	31 114 444

For an example in the use of reducers see page 17.

**Elbows 45°**

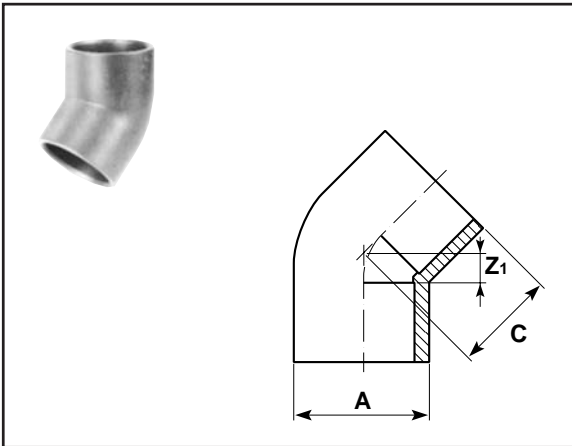

Size	A	C	Z <sub>1</sub>	gms	Code
16	21	19	5	5	31 119 305
20	25	22	6	7	31 119 306
25	31	26	7	14	31 119 307
32	40	31	8	27	31 119 308
40	50	38	10	54	31 119 309
50	62	45	13	100	31 119 310
63	78	54	15	180	31 119 311
75	93	64	18	300	31 119 312
90	112	76	23	550	31 119 313
110	136	90	26	950	31 119 314

**Elbows 90°**

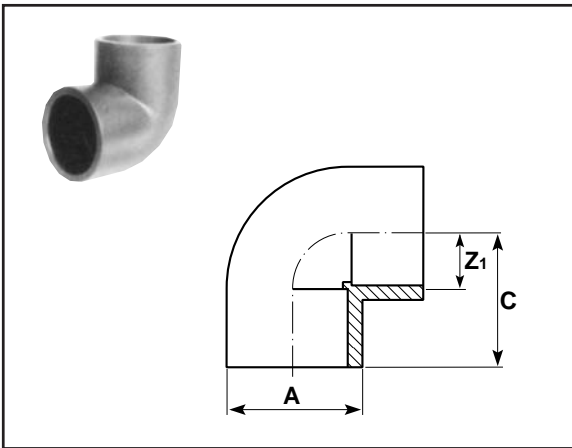

Size	A	C	Z <sub>1</sub>	gms	Code
16	21	24	10	6	31 115 305
20	25	28	12	10	31 115 306
25	31	33	14	17	31 115 307
32	40	40	18	35	31 115 308
40	50	49	22	68	31 115 309
50	62	60	27	129	31 115 310
63	78	73	34	230	31 115 311
75	93	86	40	385	31 115 312
90	111	102	49	690	31 115 313
110	136	124	60	1220	31 115 314

**Bends 90°**

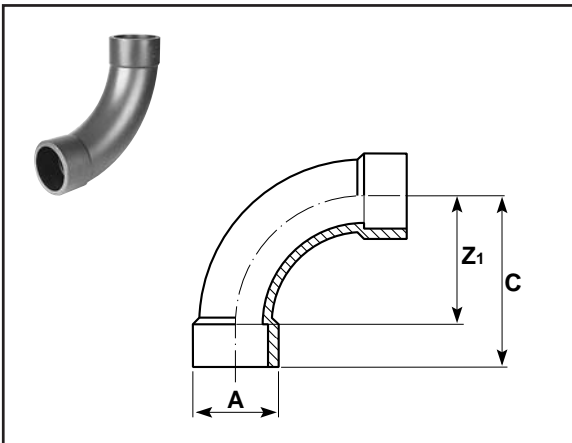

Size	A	C	Z <sub>1</sub>	gms	Code
16	21	47	32	12	31 118 305
20	26	57	40	18	31 118 306
25	33	69	50	38	31 118 307
32	41	87	64	75	31 118 308
40	51	107	80	135	31 118 309
50	62	132	100	245	31 118 310
63	78	165	126	470	31 118 311
75	93	195	150	810	31 118 312
90	111	234	180	1350	31 118 313
110	140	284	220	2570	31 118 314

**Dropper bends 180°**

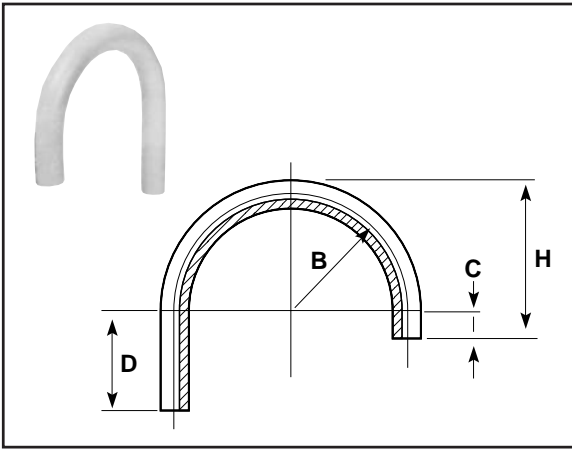

Size	B	C	D	H	Dev length	gms	Code
16	64,0	17,0	90,0	73,0	308	20	31 312 305
20	70,0	20,0	90,0	80,0	329	28	31 312 306
25	75,0	23,0	90,0	85,5	348	36	31 312 307
32	96,0	26,0	160,0	144,0	487,6	136	31 312 308

**Tees 90° equal**

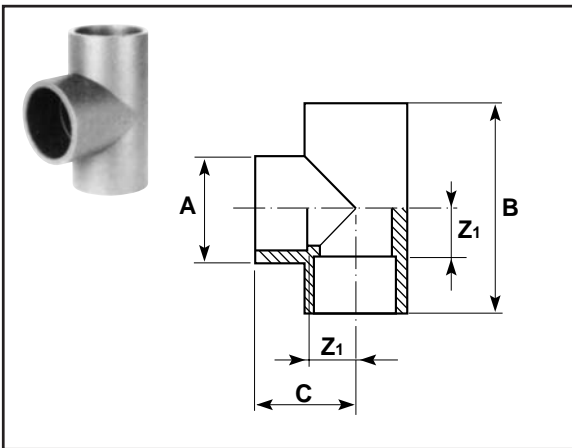

Size	A	B	C	Z <sub>1</sub>	gms	Code
16	21	47	24	10	7	31 122 305
20	25	56	28	12	12	31 122 306
25	31	67	33	14	24	31 122 307
32	40	81	41	18	48	31 122 308
40	50	98	49	22	87	31 122 309
50	62	119	60	27	160	31 122 310
63	78	146	73	34	300	31 122 311
75	93	172	86	40	510	31 122 312
90	111	204	102	49	900	31 122 313
110	136	248	124	60	1650	31 122 314

**Tees 90° reducing**

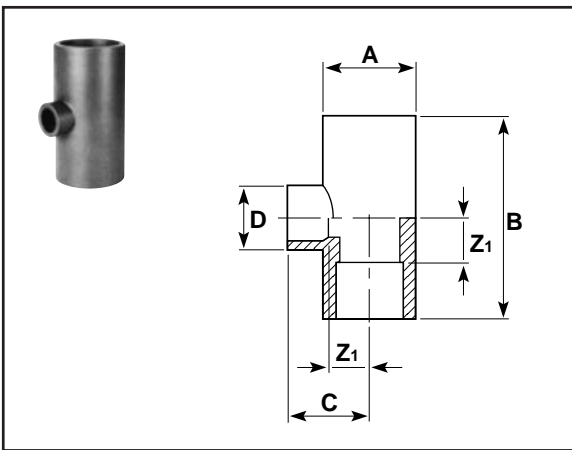

Size	A	B	C	D	Z <sub>1</sub>	gms	Code
20-16	25	56	26	21	12	12	31 124 412
25-16	31	67	28	21	14	22	31 124 414
25-20	31	67	31	25	14	22	31 124 415
32-16	40	81	32	21	18	40	31 124 417
32-20	40	81	35	25	18	40	31 124 418
32-25	40	81	37	31	18	41	31 124 419
40-20	50	98	39	25	22	72	31 124 421
40-25	50	98	41	31	22	72	31 124 422
40-32	50	98	45	40	22	74	31 124 423
50-20	62	119	44	29	27	140	31 124 424
50-25	62	119	46	31	27	140	31 124 425
50-32	62	119	50	40	27	140	31 124 426
63-25	78	146	53	31	34	250	31 124 429
63-32	78	146	57	40	34	250	31 124 430
63-50	78	146	67	62	34	270	31 124 432

**Caps, plain**

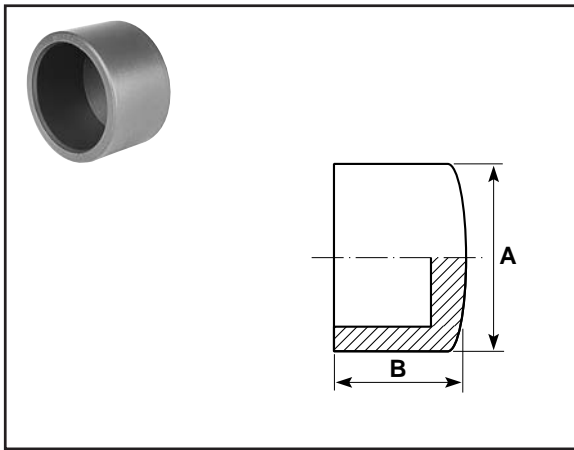

Size	A	B	gms	Code
16	21	17	3	31 149 305
20	25	21	5	31 149 306
25	32	24	8	31 149 307
32	41	29	19	31 149 308
40	50	35	30	31 149 309
50	62	41	53	31 149 310
63	78	50	106	31 149 311

**Socket unions**

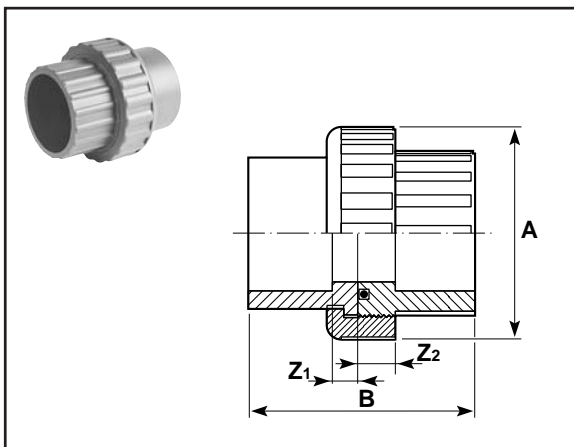

Size	A	B	Z <sub>1</sub>	Z <sub>2</sub>	gms	Code
16	33	42	3	10	19	31 205 305
20	41	47	3	10	29	31 205 306
25	50	53	3	10	46	31 205 307
32	57	64	9	10	70	31 205 308
40	72	78	10	12	140	31 205 309
50	80	92	12	14	154	31 205 310
63	102	112	14	18	270	31 205 311

*'O' ring gasket EPDM rubber, (13209) as standard. Viton (FPM) 'O' rings for conversion are available (13211).*

**Sockets** plain/BSP taper female threaded, reinforced

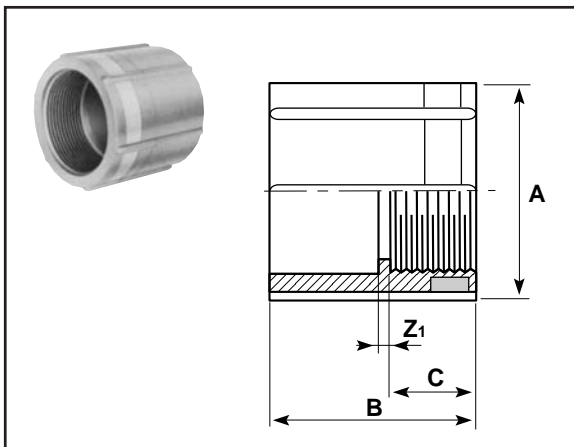

Size	A	B	C	Z <sub>1</sub>	gms	Code
20x 1/2*	28	36	16	4	12	31 101 306
25x 3/4*	36	40	18	4	19	31 101 307
32x1*	43	47	21	4	40	31 101 308

*\*Threaded size designation.*

**Female threaded adaptors** BSP taper female threaded reinforced

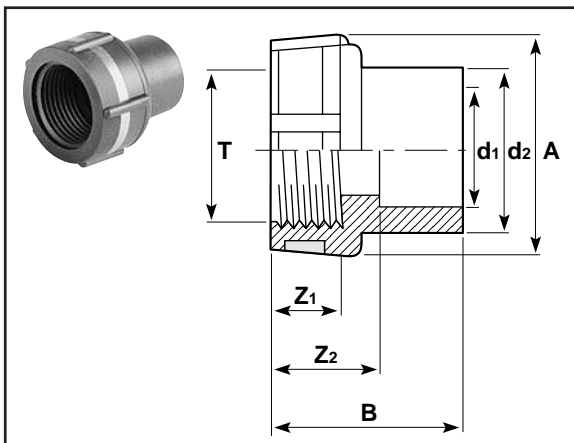

Size	d <sub>2</sub>	d <sub>1</sub>	T*	A	B	Z <sub>1</sub>	Z <sub>2</sub>	gms	Code
16-12-	3/8	23	28	11	16	7	31 153 331		
20-16-	1/2	28	34	15	20	14	31 153 333		
25-20-	3/4	35	39	16	22	21	31 153 335		
32-25-	1	44	46	19	26	42	31 153 337		
40-32-	1 1/4	55	54	21	31	69	31 153 339		
50-40-	1 1/2	63	60	21	32	108	31 153 341		
63-50-	2	78	72	26	39	169	31 153 343		

*\*Thread size designation, For spigot and socket jointing, For an example in the use of female threaded adaptors see page 17.*

**Female composite unions** ABS/brass, BSP parallel female thread

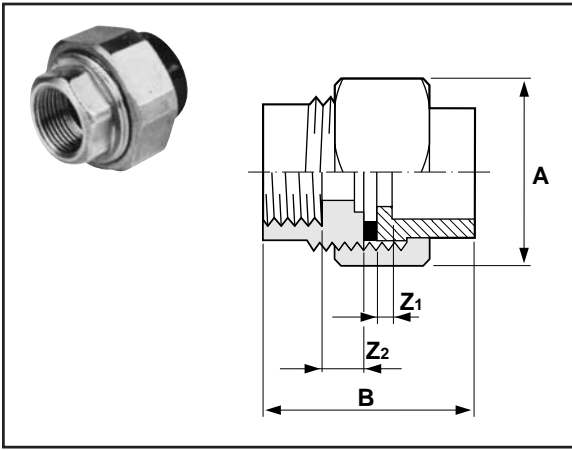

Size	A	B	Z <sub>1</sub>	Z <sub>2</sub>	gms	Code
16x 3/8*	32	37	3	9	100	31 216 305
20x 1/2*	40	42	3	9	165	31 216 306
25x 3/4*	48	48	3	10	250	31 216 307
32x1*	55	59	9	31	310	31 216 308
40x1 1/4*	65	68	10	11	450	31 216 309
50x1 1/2*	78	76	12	12	800	31 216 310
63x2*	88	90	14	14	950	31 216 311

\*Thread sizes designation. Brass retaining nut & EPDM rubber seal.

**Male composite unions** ABS/brass, BSP taper male thread

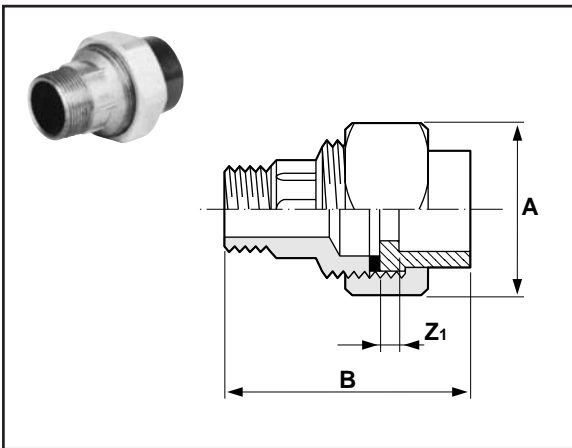

Size	A	B	Z <sub>1</sub>	gms	Code
16x 3/8*	32	48	3	105	31 217 305
20x 1/2*	40	54	3	175	31 217 306
25x 3/4*	48	74	3	320	31 217 307
32x1*	55	86	8	420	31 217 308
40x1 1/4*	65	93	10	620	31 217 309
50x1 1/2*	78	109	12	1000	31 217 310
63x2*	88	125	14	1200	31 217 311

\*Thread sizes designation. Brass retaining nut & EPDM rubber seal.

**Wallbrackets** ABS/brass body

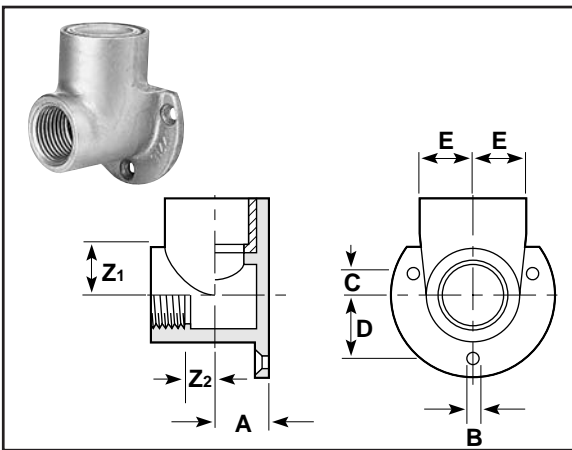

Size	A	B	C	D	E	Z <sub>1</sub>	Z <sub>2</sub>	gms	Code
16-3/8*	15	4,5	6	19	18,0	17	9	180	31 422 326
20-1/2*	16,5	4,5	6	19	19,5	18	9	185	31 422 327
25-1/2*	20	4,5	5	24	22,5	19	11	215	31 422 328
25-3/4*	20	4,5	5	24	22,5	19	11	200	31 422 329

\* Thread sizes designation.  
Bolt/Screw size M5/2BA/No.10.

**Wallbrackets multiport** aluminium

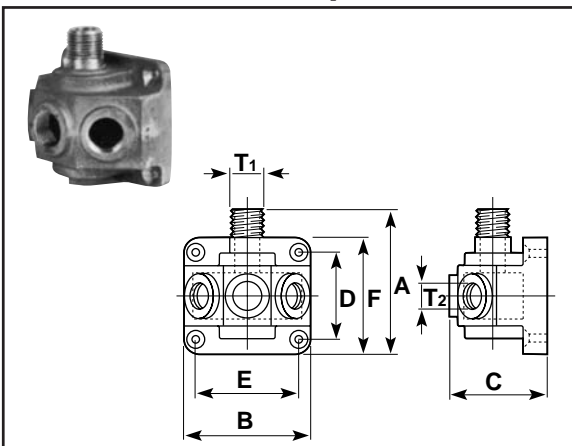

Size	A	B	C	D	E	F	T <sup>1</sup> <sub>BSP</sub>	T <sup>2</sup> <sub>BSP</sub>	gms	Code
3/4x1/2	76	84	94	56	65	56	3/4	1/2	330	31 429 122

Bolt/Screw size M5/2BA/No.10.

### Stub flanges serrated face

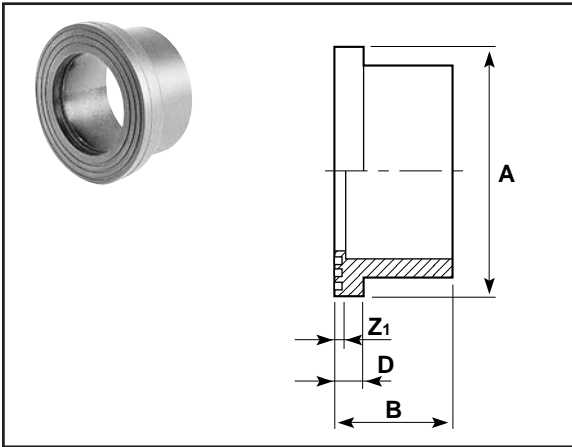

Size	A	B	D	Z <sub>1</sub>	gms	Code
32	50	29	10	6	19	31 135 308
40	61	35	8	3	36	31 135 309
50	73	40	8	3	60	31 135 310
63	90	47	14	8	100	31 135 311
75	106	53	15	8	150	31 135 312
90	125	64	16	10	240	31 135 313
110	150	75	18	11	370	31 135 314

### Blank flanges

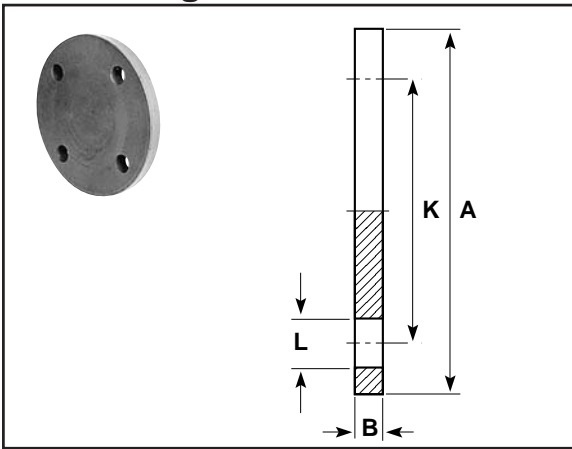

BS 4504: 16/3 (DIN 2501 16 bar/PN 16)

No. size	A	B	K	L	Holes	gms	Code
32	115	13	85	14	4	139	11 323 308
40	140	13	100	18	4	204	11 323 309
50	150	13	110	18	4	237	11 323 310
63	165	20	125	18	4	447	11 323 311
75	185	20	145	18	4	568	11 323 312
90	200	20	160	18	8	645	11 323 313
110	210	20	180	18	8	715	11 323 314

Blanking flanges are manufactured from grey ABS and must be used with the appropriate backing ring.

### Backing rings Galvanized mild steel. Drilled to DIN 2501: Sheet 1: 1972 (BS4504: Section 1: 1989 Table II)

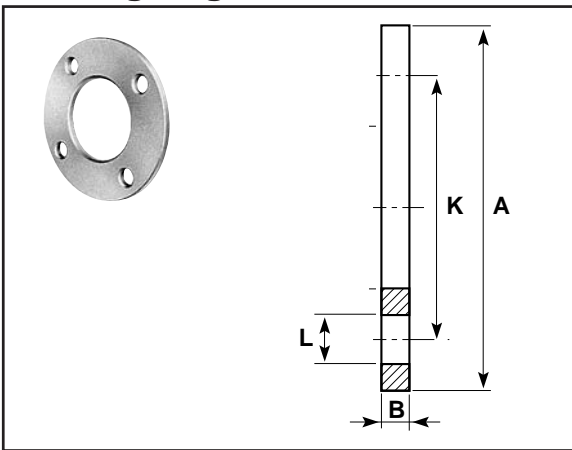

Size	A	B	K	L	Holes	gms	Code
32	115	6	85	14	4	394	13 421 308
40	140	6	100	18	4	579	13 421 309
50	150	6	110	18	4	641	13 421 310
63	165	8	125	18	4	976	13 421 311
75	185	8	145	18	4	1204	13 421 312
90	200	8	160	18	8	1245	13 421 313
110	220	8	180	18	8	1383	13 421 314

### Flat gaskets/stub flanges

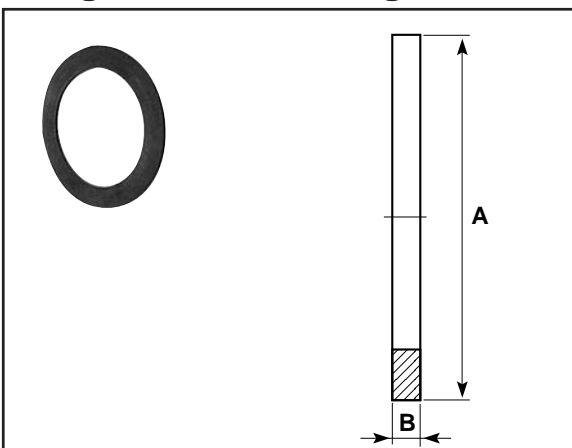

Size	A	B	gms	EPDM Code
32	50	2	4	13 411 308
40	71	2	4	13 411 309
50	73	2	7	13 411 310
63	90	3	10	13 411 311
75	106	3	20	13 411 312
90	125	3	30	13 411 313
110	150	4	40	13 411 314



**Valve support plates** Galvanized mild steel. Drilled to DIN 2501: Sheet 1: 1972 (BS4504: Section 1: 1989 Table II)

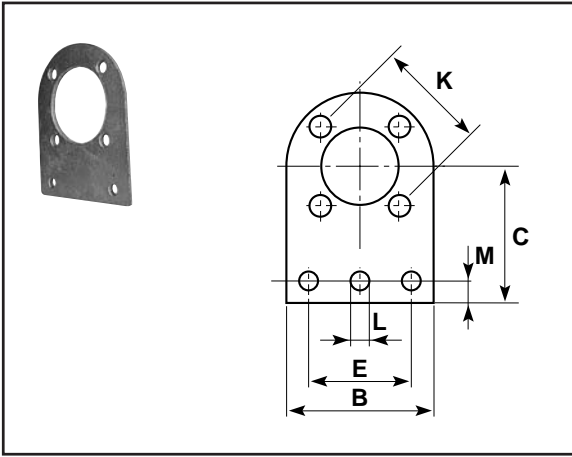

Size	B	C	E	K	L	M	N	No. Holes	gms	Code
32	115	98	76	85	14	16	2	4	860	31 459 308
50	150	127	100	110	18	22	2	4	1480	31 459 310
63	165	134	100	125	18	22	2	4	2100	31 459 311
75	185	143	126	145	18	22	2	4	2500	31 459 312
90	200	150	126	160	18	22	2	8	2660	31 459 313
110	220	159	152	180	18	22	3	8	2960	31 459 314

**Cobra Pipe Clips**

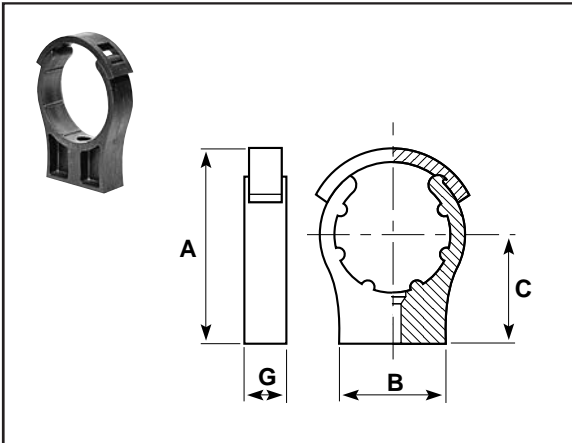

Size	A	B	C	G	Bolt/screw		gms	Code
					Size			
*16	-	35	25	16	M4/3BA/No 8		7	13 434 305
*20	-	35	30	16	M5/1BA/No 10		8	13 434 306
*25	-	35	35	17	M5/1BA/No 10		11	13 434 307
32	-	40	40	17	M5/1BA/No 10		14	13 434 308
40	-	45	45	20	M5/1BA/No 10		21	13 434 309
50	85	50	50	21	M6/0BA/No 10		30	13 434 310
63	102	60	60	21	M6/0BA/No 10		42	13 434 311
75	122	70	70	31	M8		94	13 434 312
90	148	80	90	31	M8		121	13 434 313
110	171	90	96	35	M8		185	13 434 314

*\*Without retaining clip. Bolts/screws not supplied.*

**Air-Line Xtra Solvent cement / MEK Cleaner**



**MEK Cleaner**

Litres	Code
0.5	03 463 395

**Quick Drying Solvent Cement**

ML	Code
125	31 464 394
500	31 464 395

*Note: Use only Durapipe Air-Line Xtra solvent cement for jointing the Durapipe Air-Line Xtra system.*

**Double union ball valves** Manual – Plain sockets with NBR seals

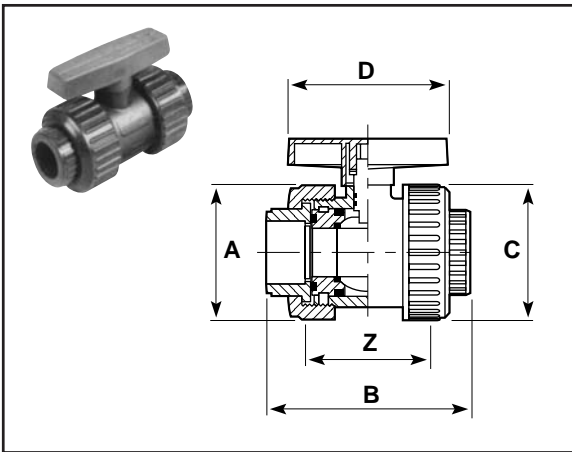

Size mm	Z	A	B	C	D	gms	Code
16	71	51	101	48	81	170	31 882 305
20	67	51	101	48	81	165	31 882 306
25	79	63	119	65	87	250	31 882 307
32	86	73	134	69	101	360	31 882 308
40	101	105	161	88	127	850	31 882 309
50	98	105	160	88	127	820	31 882 310
63	118	135	191	108	151	1560	31 882 311

12.5 bar rated @ 20°C  
N.B. See note page 4.

**Electrically actuated** (220-240 volt) Plain sockets with NBR seals

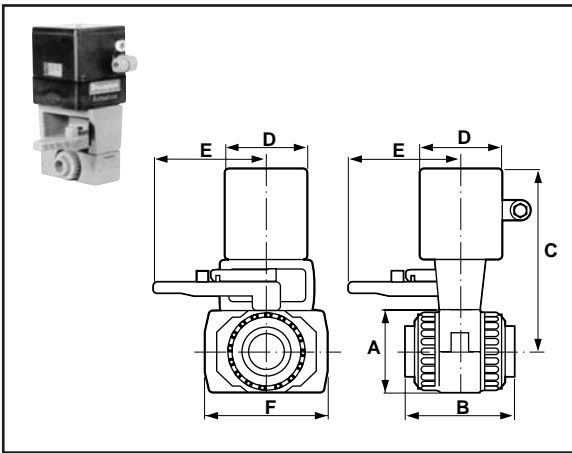

Size mm	A	B	C	D	E	F	gms	Code
16	52	101	237	122	168	140	4670	31 748 305
20	52	101	237	122	168	140	4665	31 748 306
25	70	119	246	122	168	140	4790	31 748 307
32	76	134	289	122	168	140	4900	31 748 308
40	106	161	264	122	168	180	5630	31 748 309
50	106	160	264	122	168	180	5550	31 748 310
63	142	191	282	122	168	180	6300	31 748 311

110v Order Code 787.

**Pneumatically actuated** (plain sockets with NBR seals)

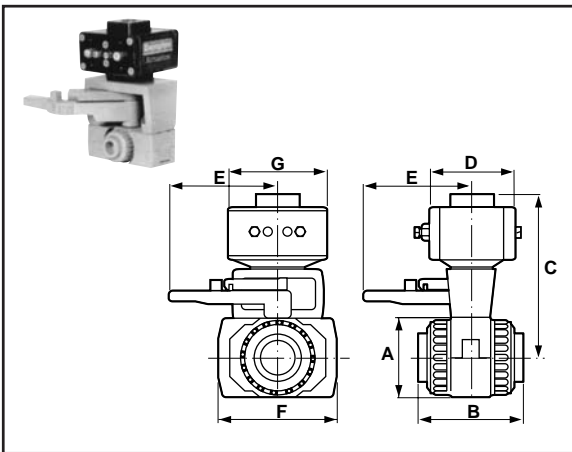

**Double Acting**

Size mm	A	B	C	D	E	F	G	gms	Code
16	52	101	198	102	168	140	121	2370	31 746 305
20	52	101	198	102	168	140	121	2365	31 746 306
25	70	119	207	102	168	140	121	2500	31 746 307
32	76	134	210	102	168	140	121	2600	31 746 308
40	106	161	225	102	168	180	121	3330	31 746 309
50	106	160	225	102	168	180	121	3250	31 746 310
63	142	191	243	102	168	180	121	4000	31 746 311

**Fail Safe Closed (or Fail Safe Open)**

Size mm	A	B	C	D	E	F	G	gms	Code
16	52	101	198	102	168	140	121	2870	31 747 305
20	52	101	198	102	168	140	121	2865	31 747 306
25	70	119	207	102	168	140	121	3000	31 747 307
32	76	134	210	102	168	140	121	3100	31 747 308
40	106	161	240	127	168	180	150	5330	31 747 309
50	106	160	240	127	168	180	150	5250	31 747 310
63	106	191	258	127	168	180	150	6000	31 747 311

Fail Safe Open available on request.

**Diaphragm valves** (manual – plain spigot ends, Nitrile diaphragm)

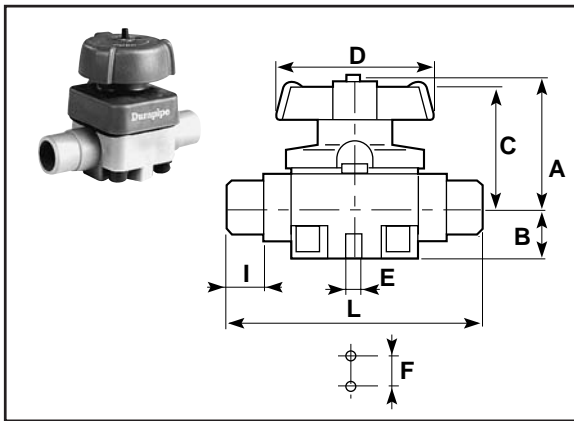

Size	A	B	C	D	E	F	I	L	gms	Code
20	95	26	88	90	M6	25	16	124	1000	31 627 306
25	95	26	88	90	M6	25	19	144	1000	31 627 307
32	95	26	88	90	M6	25	23	154	1000	31 627 308
40	126	40	116	115	M8	45	27	174	2000	31 627 309
50	126	40	116	115	M8	45	32	194	2000	31 627 310
63	148	40	136	140	M8	45	39	224	2000	31 627 311
75	225	55	220	215	M12	100	44	284	8000	31 627 312

**Pneumatically actuated diaphragm valves** (double acting/fail safe open) FPM

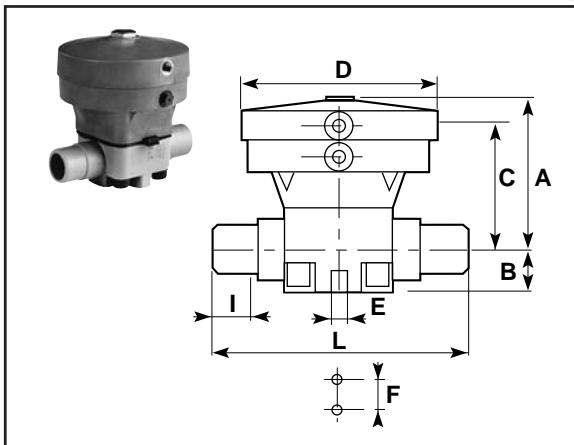

Size	A	B	C	D	E	F	I	L	gms	Code
20	146	26	120	126	M6	25	16	124	1000	31 777 306
25	146	26	120	126	M6	25	19	144	1000	31 777 307
32	146	26	120	126	M6	25	23	154	1000	31 777 308
40	202	40	133	155	M8	45	27	174	3000	31 777 309
50	202	40	133	155	M8	45	32	194	3000	31 777 310
63	235	40	156	210	M8	45	39	224	5000	31 777 311
75	305	55	252	258	M12	100	44	284	16000	31 777 312

**Pneumatically actuated diaphragm valves** (fail safe closed) FPM

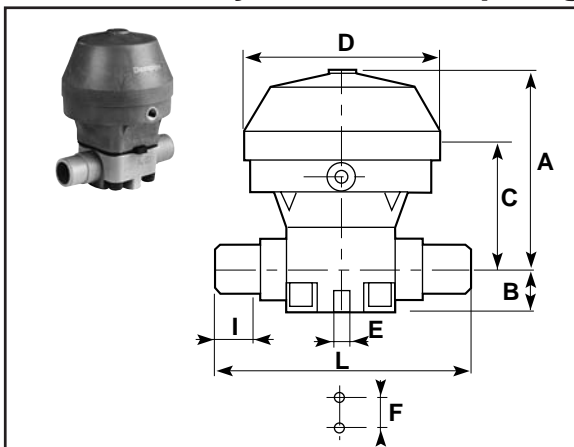

Size	A	B	C	D	E	F	I	L	gms	Code
20	148	26	66	126	M6	25	16	124	1900	31 776 306
25	148	26	66	126	M6	25	19	144	1900	31 776 307
32	148	26	66	126	M6	25	23	154	1900	31 776 308
40	203	40	103	155	M8	45	27	175	4000	31 776 309
50	203	40	103	155	M8	45	32	195	4000	31 776 310
63	254	40	125	210	M8	45	39	225	7000	31 776 311
75	325	55	187	258	M12	100	44	285	35000	31 776 312

### Manual Butterfly Valve

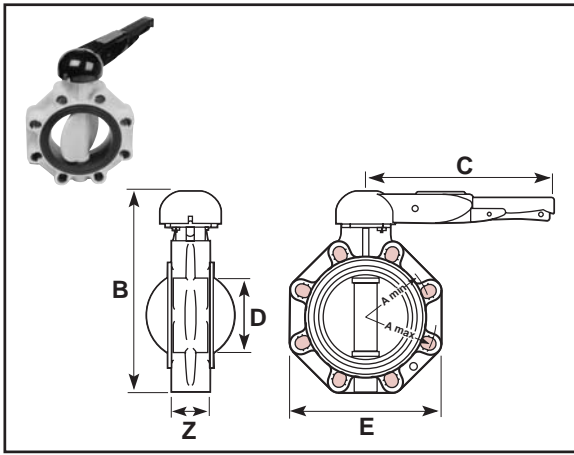

Valve Size mm	A	B	C	D	E	F	G	Weights	
								kg	Code
63	200	33	74	120	107	43	33	1.50	73 683 107
75	200	33	74	130	127	46	33	1.80	73 683 108
90	200	33	74	140	142	46	33	1.96	73 683 109
110	200	33	74	150	162	52	33	2.27	73 683 110

### Electrically Actuated (220-240 volt)

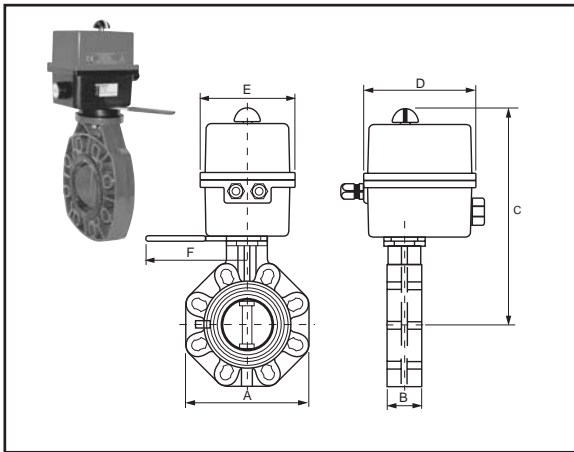

Valve Size mm	DN	A	B	C	D	E	F	Weights	
								kg	Code
75	65	165	46	319	150	127	150	5.08	73 731 108
90	80	185	49	333	150	127	150	5.24	73 731 109
110	100	211	56	347	150	127	150	5.50	73 731 110

### Pneumatically Actuated (double acting or fail safe closed)

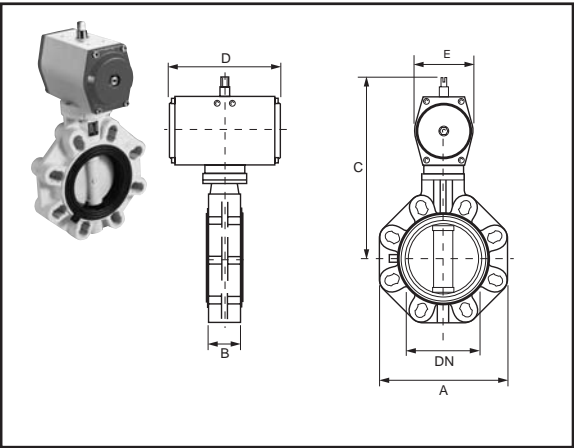

Double Acting									
Size	mm	DN	A	B	C	D	E	kg	Code
75	65	165	46	254	155	83		3.2	73 729 108
90	80	185	49	276	177	91		4.5	73 729 109
110	100	211	56	326	216	120		6.2	73 729 110

Fail Safe Closed (or Fail Safe Open)									
Size	mm	DN	A	B	C	D	E	kg	Code
75	65	165	46	242	133	70		4.6	73 730 108
90	80	185	49	256	133	70		8.3	73 730 109
110	100	211	56	282	155	83		10.9	73 730 110

Fail Safe Open available on request.

**Notes**