

# Quick Exhaust Valve(QE)



## SQE Series



## How to Order

**SQE**

**3 000- 03**

1 Quick Exhaust

2 Body Size

2 - 1/4

3 - 3/8

4 - 1/2

3 Port Size

02 - Rc(PT)1/4"

03 - Rc(PT)3/8"

04 - Rc(PT)1/2"

## Symbol

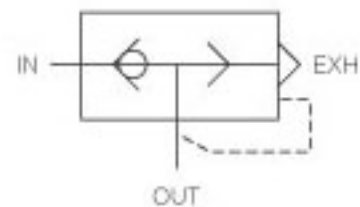

## Specification

Fluid	Compressed air
Max. supply pressure	1.5MPa[15.3kgf/cm <sup>2</sup> ]
Max. operating pressure	0.97MPa [9.9 kgf/cm <sup>2</sup> ]
Ambient temperature	5 ~ 60°C
Weight(g)	235

# SQE Series



## Structure / Parts

### SQE 4000

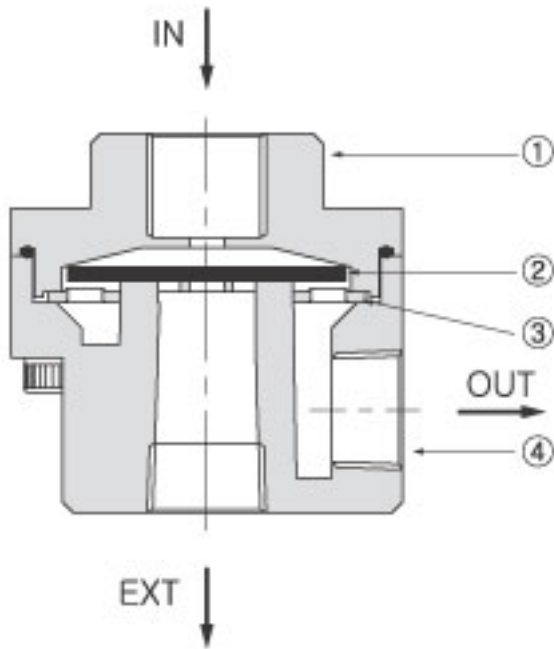

No.	PARTS	MATERIAL
1	Cover	ALDC
2	Diaphragm	NBR
3	Plate	STEEL
4	Body	ALDC

## Dimensions

### SQE 4000

